

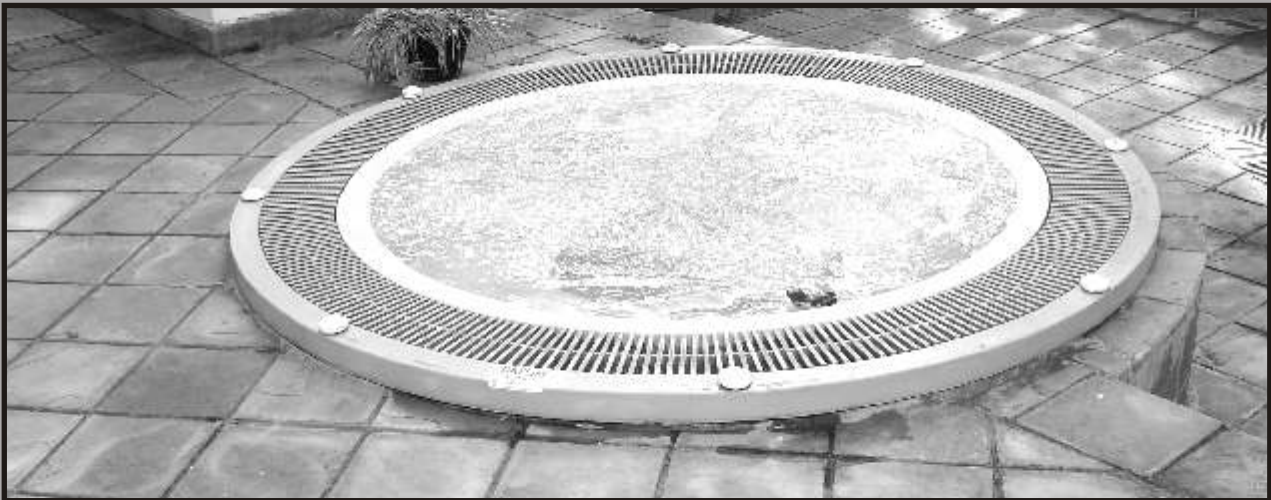

DATA SHEET

HOT SPAS



Hot spas or 'Jacuzzis' are recognised as the ultimate in personal luxury, their unique sensation and therapeutic benefits providing total relaxation in today's fast paced world. Spas are fun for all the family and using the benefit of many years experience Dayliff spas are high specification units that are simple to operate, reliable and affordable.

DAYLIFF spas are manufactured as a complete package including tub, jets, tub fittings and circulation unit. The round GRP tub comfortably accommodates up to six adults and is supplied pre-plumbed and complete with jets and outlets ready for installation. Design options include either the standard freeboard arrangement or an overflow design for those who demand a little more luxury. The tubs can also be supplied in many colours to suit the customer's choice. Particular features of the design are:-

- Reinforced self-supporting GRP tub which is long lasting, attractive and easy to install.
- Hydro air jets individually adjustable for direction and force and separate adjustable air controls.
- Individually switched heating elements for economical control of spa temperature up to 40°C.
- Exceptional jet performance provided by powerful pumps.
- Compact circulation unit incorporating main jet pump, filter circulation pump, 9kW heater, pressure sand filter and control panel all frame mounted for simple installation.

Equipment options include remote spa control facility, an LED light and a rigid fibreglass cover. Also for that added luxury a separate air-pump can be specified which supplies air directly to the spa seat.

Particular care has been taken with the design of the DAYLIFF spa to provide ease of operation and optimal performance. The cost is sensible, installation easy and the effect is remarkable....so how about a little luxury in your life!

TUB SPECIFICATION

One piece moulded reinforced GRP tub incorporating 6 peripheral hydro-air jets with individual air controls, 4 seat jets and anti-vortex suction complete with all circulation piping connections. The tub is designed for free-standing installation and needs no further support other than a firm base.

Note that separate balance tank is required for the overflow design (not provided).

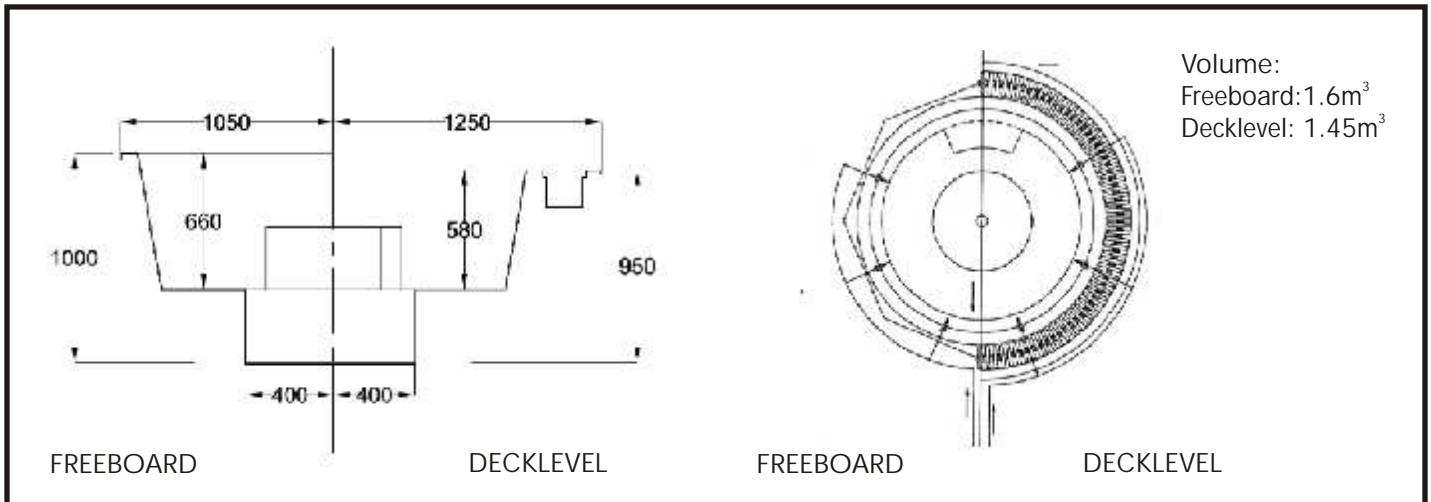

CIRCULATION UNIT SPECIFICATION

Filter: Dayliff DX500 pressure sand filter complete with multi part control valve.

Pumps: Quality QP6 centrifugal pump with 1.1kW single phase electric motor.
Quality QP3 centrifugal pump with 0.6kW single phase electric motor

Heater: 9kW in-line electrical heater incorporating 3 no 3kW heating elements.

Control Panel: Control panel in steel enclosure incorporating incoming MCB, individual MCBs for pumps, and individual MCB's for heater elements with interlock to prevent heater operation without the circulation pump. Indicator lights are incorporated for the pumps and heaters and separate contactor control is provided for remote operation. Single or three phase power supply options are available.

Electrical Supply: Maximum load 54 Amps

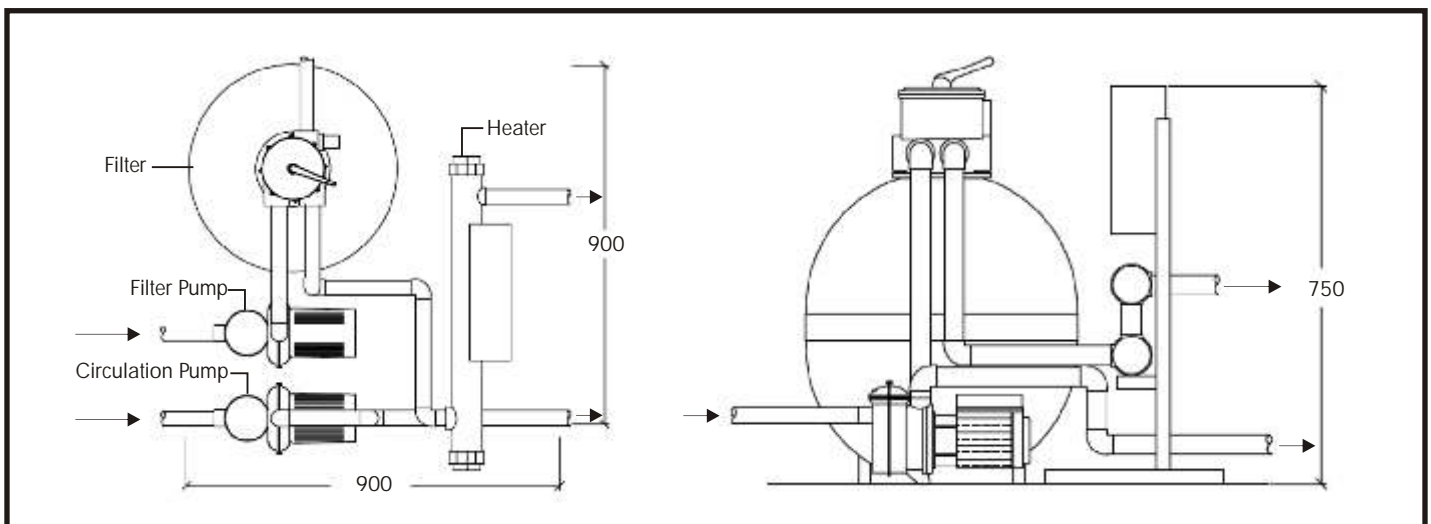

NB. Contents herein are not warranted. The right is reserved to amend specifications without notice.

AVAILABLE FROM

DP121A-05/08

D&S DAVIS & SHIRTLIFF
know H₂O through experience
www.dayliff.com

KENYA

NAIROBI - HEAD OFFICE
TEL: (254 41) 2495920, 2490861, FAX: 2490868
d&s@dayliff.com
WESTLANDS
TEL: (254 20) 4446011, 4446016, FAX: 4451038
westlands@dayliff.com
ELDORLET
TEL: (254 53) 2061306, FAX: 2062335
d&s@eld.dayliff.com
KISUMU
TEL: (254 57) 2024763, FAX: 2023103
d&s@ksm.dayliff.com

MOMBASA
TEL: (254 41) 2495920, 2490861, FAX: 2490868
d&s@msa.dayliff.com
MALINDI
TEL: (254 42) 20425, FAX: 20426
d&s@mld.dayliff.com
NAKURU
TEL: (254 51) 2213146, 2213248, FAX: 2212956
d&s@nkr.dayliff.com

ETHIOPIA

ADDIS ABABA
TEL: (251 11) 5159341/4
d&s@et.dayliff.com

ZAMBIA

LUSAKA
TEL/FAX: (260 211) 288010/1, 845010/1
lusaka@zm.dayliff.com
KITWE
TEL/FAX: (260 212) 22174/67,
kitwe@zm.dayliff.com

RWANDA

KIGALI
TEL: (250) 504039, FAX: 504033
sales@dayliff.co.rw

TANZANIA

DAR ES SALAAM
TEL: (255 22) 2112515/6, FAX: 2112513
office@tdayliff.com
ARUSHA
TEL: (255 25) 2502517/8, FAX: 2502516
office@ars.tzdayliff.com
ZANZIBAR
TEL: (255 24) 2234660/1, FAX: 2234664
office@znz.tzdayliff.com
UGANDA
KAMPALA
TEL: (256 414) 346337/8, FAX: 346335
d&s@ug.dayliff.com