



**'WG' WATER**

**PURIFIERS**



The DAYLIFF 'WG' Water Purifier is an integrated water treatment plant specifically designed to treat the majority of surface waters in small-scale domestic, institutional and commercial installations with a particular application to the removal of silt, suspended solids and bacteria. Based on many years of water treatment experience, the units are simple to operate, low cost and easy to maintain and can provide consistent water quality to WHO standards.

Features include:-

- Four stage treatment process including flocculation, settlement, filtration and chlorination providing treated water to the highest standards.
- All gravity operation option with no pumps required.
- GRP (fibreglass) construction for strength, low maintenance and indefinite life.
- High efficiency vertical flow type settlement basin incorporating sludge bleed.
- Large capacity gravity sand filter providing efficient filtration and simple operation.
- Automatic proportional feed chemical dosage using 'Dosatron' chemical feeders. These unique dosers use energy in the water flow as their power source providing accurate and consistent dosage regulated by plant output.
- In-line flow meter to adjust and monitor plant output.
- Simple in-line installation with three adjustable legs to assist leveling.
- Fully automatic control - the plant matches output to site demand.

Two installation options are offered:-

- Direct gravity feed to a clear water tank or the site supply if site conditions allow.
- Pumped supply to a header tank in which case an integral balance tank is fitted to facilitate pump control with the option of AC mains power or DC solar powered pumps being available.

With an output of up to 12000 litres a day of averagely contaminated raw water and more for lightly polluted waters, the DAYLIFF 'WG' Purifier is suitable for settlements of up to 100 people. Using only basic water treatment chemicals (Alum and Chlorine), high quality treated water is available, which combined with long life GRP construction, simple maintenance and easy installation make DAYLIFF 'WG' Purifiers the ideal solution for all small scale water treatment requirements.

## OPERATING CONDITIONS

**Capacity:** 500 l/hr or approx 12,000 litres per day at maximum output.

**Raw Water Quality:** Surface water containing suspended particles, silt and bacteria. The plant is not suitable for treatment of any dissolved solids, hardness or salinity.

**Maximum Water Temperature:** +30°C

**Inlet Pressure:** Minimum 0.5Bar, Maximum 3 Bar

## SPECIFICATIONS

**Sedimentation Basin:** 1200 litres upward flow basin with conical case and sludge bleed. Retention time is 2.4hrs at the rated flow.

**Filter:** Gravity sand filter of 0.75m<sup>3</sup> area containing approximately 0.25m<sup>3</sup> filtering media.

**Chemical Dosage:** Dosatron D15 automatic proportional feeders with a set 2% dosage rate drawing from 100l concentrate tanks. Endurance at maximum rated flow and standard concentrations is 8hrs.

**Balance Tank:** Capacity 150 litres (when fitted)

### Transfer Pump:

240V AC Pedrollo PKm60 0.37kW peripheral pump with maximum delivery pressure of 3 Bar.

12V DC Shurflo 2088 positive displacement diaphragm pump with a maximum delivery pressure of 4.5 Bar. This option includes the fitting of a PV solar module of 70-110W output, size being dependent upon delivery pressure requirement.

**Weight:** 105Kgs (empty), 1800Kgs (operating)

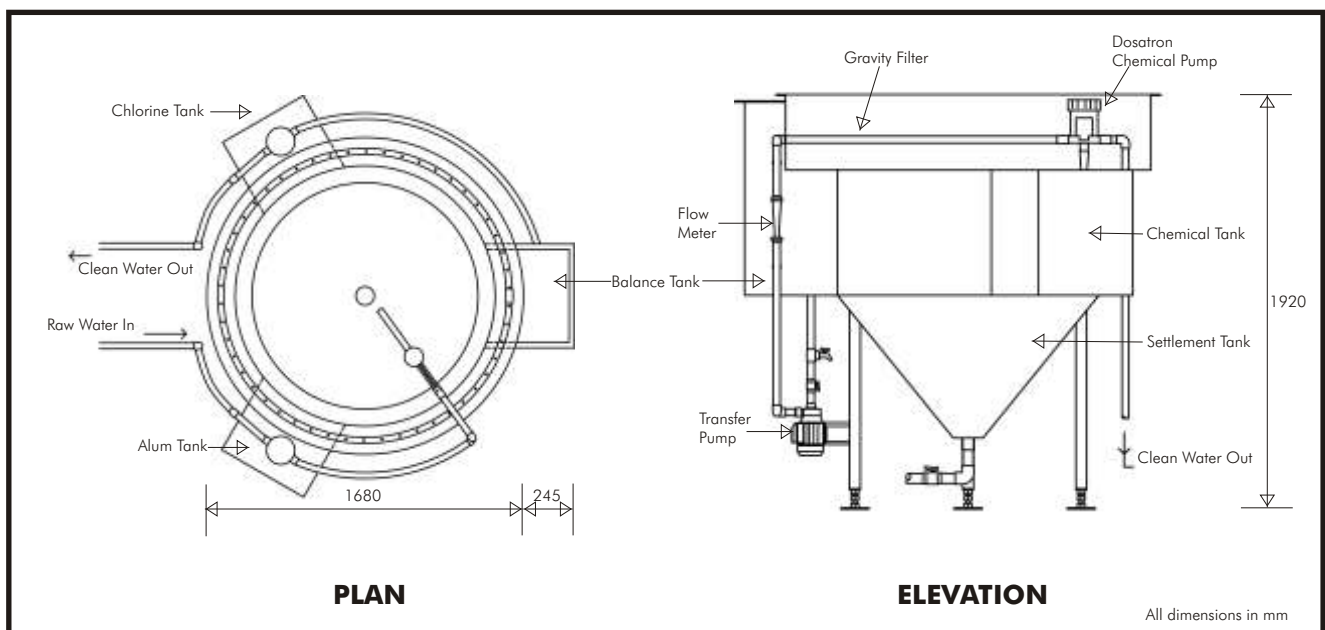

AVAILABLE FROM

BH2B-9/04



### KENYA

**NAIROBI - HEAD OFFICE**  
DUNDORI RD  
P O BOX 41762, 00100 GPO  
TEL: (254 20) 558335, 536901, FAX: 557617  
d&s@dayliff.com

### THE POOL SHOP

CENTRO HSE, RING RD WESTLANDS  
P O BOX 41762, 00100 GPO  
TEL: (254 20) 4446011, 4446016, FAX: 4442568  
poolshop@dayliff.com

### ELDORET

UGANDA RD, ELDOTUNE BLD, P O BOX 4776  
TEL: (254 53) 61306, FAX: 62335  
d&s@eld.dayliff.com

### KISUMU

OBOTE RD, P O BOX 4690,  
TEL: (254 57) 44537/8, FAX: 23103  
d&s@ksm.dayliff.com

### MOBASA

JOMO KENYATTA AVENUE P O BOX 82438,  
TEL: (254 41) 490861, 492626, 490136, FAX: 490868  
d&s@msa.dayliff.com

### UGANDA

**KAMPALA**  
JINJA RD, P O BOX 22824  
TEL: (6 41) 346337/8, FAX: 346335,  
d&s@ug.dayliff.com

### TANZANIA

**DAR ES SALAAM**  
GEREZANI RD, P O BOX 10725  
TEL: (7 22) 2112515/6, FAX: 2112513  
office@tzdayliff.com

### ZAMBIA

**LUSAKA**  
LUMUMBA RD, P O BOX 112 F/W  
Tel: (01) 288010/11, Fax: (01) 288010  
d&s@zm.dayliff.com

### RWANDA

**KIGALI**  
MUHIMA ROAD, BP 7039  
Tel: (250) 08755381  
hmuchiri@mail.com

[www.dayliff.com](http://www.dayliff.com)