

GRUNDFOS®

MADE IN DENMARK



DATA SHEET

Multistage Centrifugal Borehole Pumps

CR 10

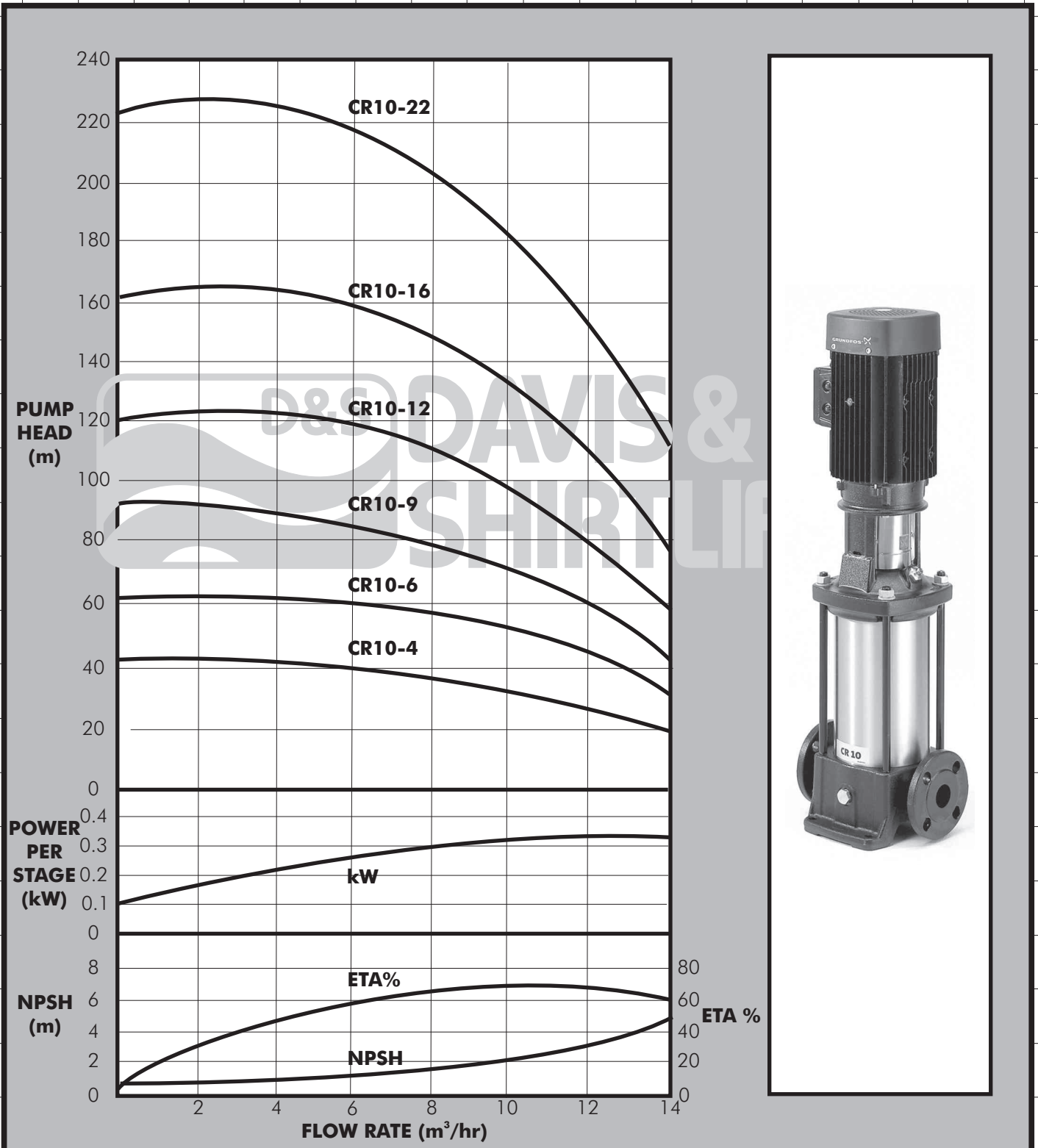

PUMP

The GRUNDFOS CR pump range are of vertical multistage in-line centrifugal design suitable for a wide range of water supply, irrigation, liquid transfer and boosting applications. The pumps are of heavy duty construction and are designed for continuous duty in commercial and industrial installations. All vital components including the impellers, intermediate chambers and shaft are made from stainless steel and the top and bottom housings from cast iron. The pump is water lubricated and is provided with a tungsten carbide faced mechanical shaft seal.

For aggressive liquids the 'N' version is available which features stainless steel top and bottom pump housings.

MOTOR

The pumps are coupled to a totally enclosed fan cooled 2-pole GRUNDFOS motor complying with IEC & DIN standards. All motors must be connected to an effective motor starter in accordance with local regulations.

Enclosure Class: IP55 **Insulation Class:** F **Voltage:** 3x380-415 V **Speed:** 2900 rpm

OPERATING CONDITIONS

Pumped liquids: Thin, clean, non-aggressive and non-explosive liquids without solid particles or fibres.

Liquid Temperature Range: - 20°C to +120°C

Max Ambient Temperature: +40°C

Max Suction Lift: According to the NPSH curve plus a safety margin of 1 m.

Max Operating Pressure: Models up to CR 10-16 - 16 Bar
CR 10-22 - 25 Bar

ELECTRICAL DATA

Model	Motor		Full Load Current (A)	I start I
	kW	HP		
CR 10-4	1.5	2.0	3.4	6.6
CR 10-6	2.2	3.0	4.8	7.3
CR 10-9	3.0	4.0	6.4	8.3
CR 10-12	4.0	5.5	8.0	9.1
CR 10-16	5.5	7.5	11.0	9.3
CR 10-22	7.5	10.0	15.2	9.5

DIMENSIONS AND WEIGHTS

Model	Dimensions (mm)						Net Weight (kg)
	B ₁	B ₂	B ₁ +B ₂	D ₁	D ₂	D ₃	
CR 10-4*	423	281	704	178	110	-	43
CR 10-6*	483	281	764	178	110	-	47
CR 10-9*	578	335	913	198	120	-	54
CR 10-12*	668	372	1040	220	134	-	67
CR 10-16**	820	391	1211	220	134	300	92
CR 10-22**	1000	391	1391	220	134	300	105

* CR10 with oval flanges

** CR10 with DIN flanges

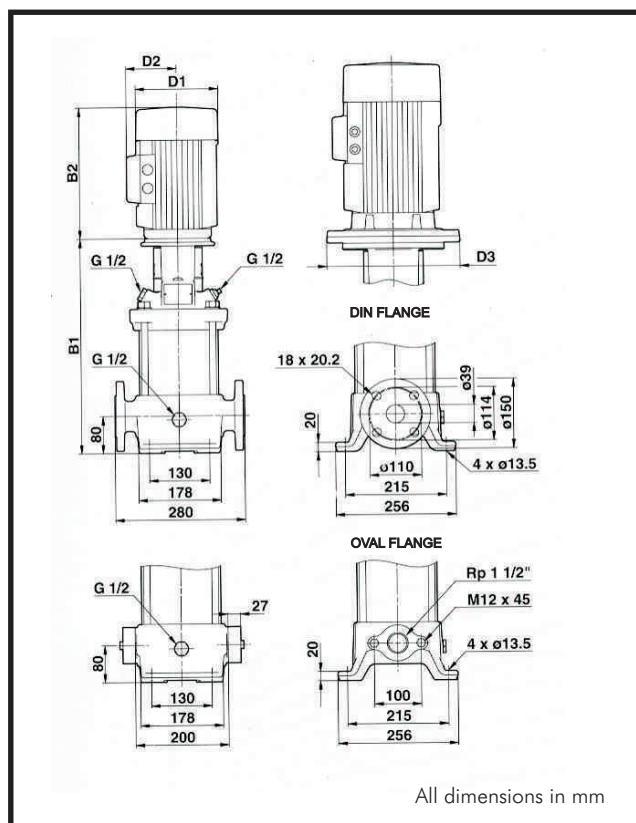

KENYA
NAIROBI - HEAD OFFICE
 TEL: (+254 20) 6968 000
headoffice@dayliff.com
NAIROBI - WESTLANDS
 TEL: (+254 20) 44480116,
westlands@dayliff.com
NAIROBI - DOWNTOWN
 TEL: (+254 20) 340102
downtown@dayliff.com
NAIROBI - KAREN
 TEL: (+254 20) 3883513
karen@dayliff.com
THIKA
 TEL: (+254 67) 20084/5
thika@dayliff.com
ELDORET
 TEL: (+254 53) 2061906
eldoret@dayliff.com

NAKURU
 TEL: (+254 51) 2213248
nkroffice@dayliff.com
KISUMU
 TEL: (+254 57) 2024763
ksmoffice@dayliff.com
KISII
 TEL: (+254 58) 2030949
kisii@dayliff.com
NAIVASHA
 TEL: (+254 50) 2030510
naivasha@dayliff.com
MACHAKOS
 TEL: (+254 40) 2021668
naivasha@dayliff.com
MERU
 TEL: (+254 64) 3131033
meru@dayliff.com

GARISSA
 TEL: (+254 46) 2102620
garissa@dayliff.com
KENYA COAST
MOMBASA - Main Office
 TEL: (+254 20) 2040432
d&smasa@dayliff.com
MALINDI
 TEL: (+254 42) 2120425
midoffice@dayliff.com
DIANI
 TEL: (+254 40) 3202181
dianioffice@dayliff.com
LAMU
 TEL: (+254 20) 2651052/56
lamu@dayliff.com

NYALI
 TEL: (+254 20) 2443357
d&s@nyali.dayliff.com
VOI
 TEL: (+254 20) 2028284
voi@dayliff.com
ETHIOPIA
ADDIS ABABA
 TEL: (+251 11) 5159341/44
d&sethiopia@dayliff.com
RWANDA
KIGALI
 TEL: (+254 20) 252 504039
rwoffice@dayliff.com

UGANDA
KAMPALA - Main Office
 TEL: (+255 414) 346337/8
d&skampala@dayliff.com
KAMPALA - NAKESERO
 TEL: (+256 392) 734633
d&snakaser@dayliff.com
GULU
 TEL: (+256 471) 433041
d&sgulu@dayliff.com
MBARARA
 TEL: (+256 753) 940 080
d&smbarara@dayliff.com

TANZANIA
DAR ES SALAAM - Main Office
 TEL: (+255 22) 2112515/6
d&sdarressalaam@dayliff.com
DAR ES SALAAM - KARIAKOO
 TEL: (+255 22) 2184867
d&skariakoo@dayliff.com
ARUSHA
 TEL: (+255 27) 2547317/8
arussha@dayliff.com
ZANZIBAR
 TEL: (+255 24) 2234660/1
zanzibar@dayliff.com
MWANZA
 TEL: (+255 28) 2541971/2
d&smwanza@dayliff.com

ZAMBIA
LUSAKA - Main Office
 TEL: (+260 211) 288010/1
d&slusaka@dayliff.com
NDOLA
 TEL: (+260 212) 610936/7
d&sndola@dayliff.com
KITWE
 TEL: (+260 212) 221747/6/7
d&skitwe@dayliff.com
LIVINGSTONE
 TEL: (+260 213) 320002/234
d&slivingstone@dayliff.com
SOUTH SUDAN
JUBA
 TEL: (+211 956) 397 070
juba@dayliff.com