



DDV 60 Well Pumps



Installation & Operating Manual

INDEX

1. PUMP SPECIFICATIONS	1
2. INSTALLATION	2
3. PUMP OPERATION	3
4. MAINTENANCE	3
5. TROUBLE SHOOTING	4
6. TERMS OF WARRANTY	5

Thank you for choosing Dayliff DDV60 pump. The pump has been manufactured to the highest standards and if operated correctly should give many years of efficient and trouble free service. Careful reading of this instruction manual is therefore extremely important and if you have any queries please refer them to your retailer.

1. PUMP SPECIFICATION

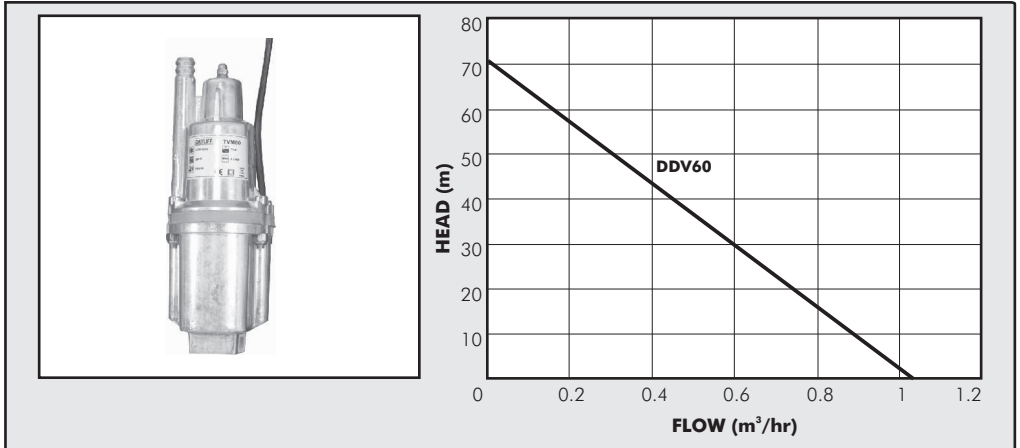

Pump

The Dayliff DDV well pump is a unique design of submersible pump specially applicable for water supply from domestic wells. The pump is of positive displacement type using a vibrating diaphragm which is efficient and provides high output pressure. Of compact construction and robust design, the pump is also easily disassembled for maintenance and is securely installed by suspension on a rope in the well.

Pump housing construction is aluminum throughout, the diaphragm and check valve being made of rubber. 9m of drop cable is provided as integral with the pump.

Motor

Pumps are fitted to a continuously rated electric motor. It should be connected to single phase power supply through a 5A fuse or MCB.

Voltage : 1X 240V

Enclosure Class: IP68

Insulation Class: B

Pump Data

Pump	Input Power	Outlet	Weight
DDV60	0.25kW	1/2"	4kg

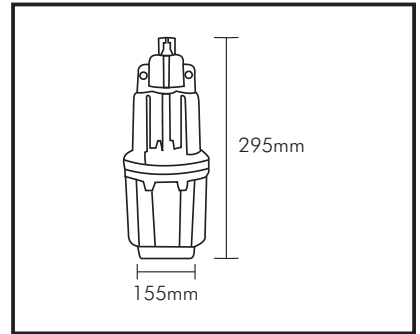

2. INSTALLATION

- The pump should be suspended freely in the well using the supplied cord tied through the holes provided in the pump casing and fixed to a support at the surface. It should never be suspended by the drop cable or delivery hose and there should be no tension applied to either of these items.
- The pump should be immersed a minimum of 50cms under water and it should be a least 50cms from the well floor to minimize the possibility of particle ingress.
- Water delivery should be through an 18-22mm flexible hose connected to the pump outlet using a jubilee type clip and the fitting of a non-return valve close to the pump is recommended for well depths greater than 5m. It is important to note that the pump vibrates during operation and rigid fixing to a pipe or mounting plate must be avoided.
- Once installed it is recommended that the suspension rope, drop cable and outlet hose be tied together with cable clips or tape at approx 1m spacings with the first tie approx 200mm above the pump.

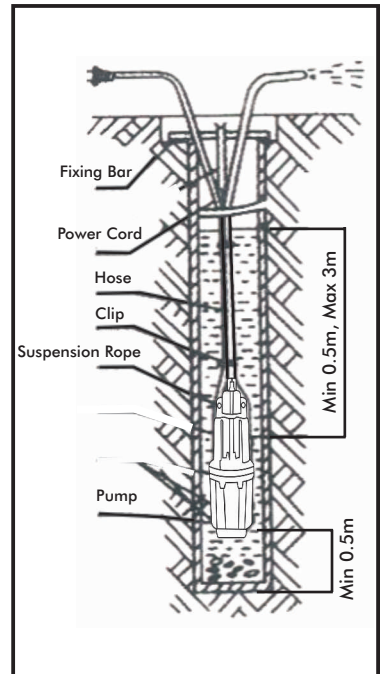

- The power cord should be connected directly to mains power through a 5A fuse or MCB.
- Where there is possibility of unreliable power supply voltage the fitting of a Sollatek power protection controller is highly recommended. Continuous operation at low voltage can lead to motor failure.

3. PUMP OPERATION

- The pump does not require any initial lubrication and is self priming once immersed in water.
- Water discharge should be monitored and if silted water is noted the pump should be switched off and its position in relation to the well/pit bottom checked and raised if necessary. If the pumped water contains any sand or fine stones pump damage will result.
- The diaphragm will tend to wear over time. If pump performance is noted to deteriorate the impeller and check valve should be replaced (see Section 4)



To preserve pump life pump operation should be limited to a maximum of 2 hours followed by a half an hour shutdown. The pump should not be used continuously for a long period of time and total use of the pump should not exceed 12 hours in a 24 hour period.

4. MAINTENANCE

- The pump is water lubricated and so no routine maintenance is necessary.
- The pump is fitted with a rubber diaphragm and a rubber check valve that will wear over time. They can be replaced by opening the housing tie bolts, the diaphragm being replaced by removing the shaft nut and the old diaphragm and the check valve by undoing from its location at the top of the pump housing. It is recommended that both parts are replaced together, one set being provided with each pump and additional sets being available from your dealer. Do not over tighten the housing bolts on re-assembly and it is recommended that the pump be tested in a container before reinstallation in the well to check it is performing satisfactorily.
- If the pumped water is silted the inlet ports may become blocked. They should be cleaned with a blunt pointed tool to avoid damaging the rubber check valve.



Electrical Supply MUST be switched off whenever maintenance is being carried out.

5. TROUBLE SHOOTING GUIDE

PROBLEM

POSSIBLE CAUSE

SOLUTION

Water discharge decreases, pump's humming suddenly increases

Rubber diaphragm is worn-out

Replace rubber diaphragm

Water discharge decreases, pump's humming is normal

Rubber check valve is worn-out

Replace rubber check valve

Pump does not run, power supply protection trips

Electrical short circuit

Check pump motor

Pump does not run

No mains supply

Check mains supply

Pump runs with low or no flow

Pump suction obstructed

Clean suction

Delivery hose obstructed

Check delivery hose and rectify

Delivery head is too high

Reduce delivery head

6. TERMS OF WARRANTY

i) General Liability

- In lieu of any warranty, condition or liability implied by law, the liability of Davis & Shirliff (hereafter called the Company) in respect of any defect or failure of equipment supplied **is limited to making good by replacement or repair** (at the Company's discretion) defects which under proper use appear therein and arise solely from faulty design, materials or workmanship within a specified period. This period commences **immediately after the equipment has been delivered to the customer** and at its termination all liability ceases. Also the warranty period will be assessed **on the basis of the date that the Company is informed of the failure**.
- This warranty applies solely to equipment supplied and **no claim for consequential damages**, however arising, will be entertained. Also the warranty specifically excludes defects caused by fair wear and tear, the effects of careless handling, lack of maintenance, faulty installation, incompetence on the part of the equipment user, Acts of God or any other cause beyond the Company's reasonable control. Also, any repair or attempt at repair carried out by any other party **invalidates all warranties**.

ii) Standard Warranty

General Terms

If equipment failure occurs in the normal course of service having been competently installed and when operating within its specified duty limits warranty will be provided as follows:-

- **Up to six months - The item will be replaced or repaired at no charge.**
- **Over six months, less than twelve months - The item will be replaced or repaired at a cost to the customer of 50% of the Davis & Shirliff market price.**

The warranty on equipment supplied or installed by others is conditional upon the defective unit **being promptly returned free to a Davis & Shirliff office** and collected thereafter when repaired. No element of site repair is included in the warranty and any site attendance costs will be payable in full at standard chargeout rates. Also proof of purchase including the purchase invoice must be provided for a warranty claim to be considered.

DAYLIFF is a brand of **Davis & Shirliff**

for enquiries contact

Davis & Shirliff, Ltd.

P.O. Box 41762 - 00100, Nairobi, Kenya

Tel: 6968000/ 0711 079 000

or visit

www.dayliff.com

for details of the nearest branch or stockist