



# **DI/DIN Multistage Centrifugal Pumps**



## **Installation & Operating Manual**



# INDEX

<b>1. MODEL NUMBERING AND NAMEPLATE</b>	1
<b>2. PUMP APPLICATION</b>	1
<b>3. TECHNICAL DATA</b>	3
<b>3.1 Temperature</b>	2
<b>3.2 Minimum inlet pressure - NPSH</b>	2
<b>3.3 Minimum nominal flow rate</b>	3
<b>3.4 Number of start per hour</b>	3
<b>3.5 Maximum operating pressure</b>	4
<b>4. INSTALLATION</b>	5
<b>5. ELECTRICAL CONNECTIONS</b>	6
<b>6. START-UP</b>	7
<b>7. MAINTENANCE</b>	8
<b>8. TROUBLE SHOOTING</b>	9
<b>9. WARRANTY</b>	11

**Thank you for choosing Dayliff DI/DIN pump. The pump has been manufactured to the highest standards and if operated correctly should give many years of efficient and trouble free service. Careful reading of this instruction manual is therefore extremely important and if you have any queries please refer them to your retailer.**

## 1. MODEL NUMBERING AND NAMEPLATE

**DI/DIN 5 16 SQQE**

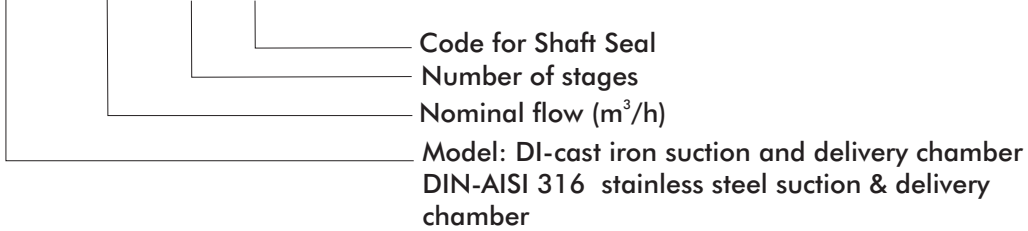

1. Pump Model
2. Rated Power
3. Speed
4. Maximum Head
5. Optimum Flow
6. Optimum Range
7. Serial Number
8. Current

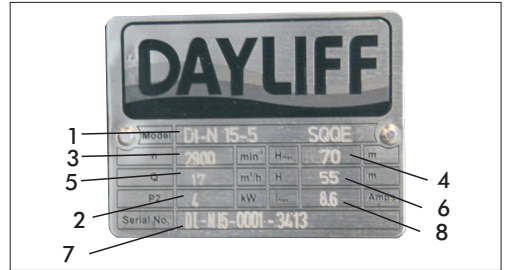

## 2. PUMP APPLICATION



***These pumps are not designed to be used with abrasive, solid containing, explosive and corrosive liquids For special application, please contact your supplier or the factory.***

Dayliff DI/DIN in-line booster pumps are designed for a wide range of applications in various industries – for water treatment, water boosting, water supply, cooling, cleaning, etc. The pumps are designed for use with clean, viscous and non-explosive liquids that do not contain abrasive matter.

## 3. TECHNICAL DATA

### 3.1 TEMPERATURE



*If ambient temperatures are above +40°C, the motor's output must be decreased to compensate for less effective cooling, and may have to be replaced with a bigger size motor.*

- Ambient temperature: 0°C to +40°C.
- Liquid temperature: -15°C to +120°C

### 3.2 MINIMUM INLET PRESSURE - NPSH



*Stop operation of the pump if cavitation occurs. Cavitation will cause pump damage which is not subject to warranty.*

To avoid cavitation, make sure that there is a minimum pressure on the suction side of the pump.

#### **NPSHA: Net Positive Suction Head Available**

The net positive suction head available is a function of the pump suction arrangement.

#### **NPSHR: Net Positive Suction Head Required**

The net positive suction head required is a function of the pump design at the operating point as given on the pump performance curve.

#### **NPSHA=Ha-Hs-Hf-Hv-Hst**

**Ha:** Standard barometric pressure at sea level (10m at sea level)

**Hs:** Suction lift.

**Hf:** Friction loss in suction pipe.

**Hst:** Safety margin (minimum: 1 m head)

**Hv =  $K_T + K_H$ :** Vapor pressure where;

**$K_T$ :** Flow resistance due to liquid temperature.

**$K_H$ :** Flow resistance due to elevation above sea level. If the liquid is water, consult the tables below to determine the values of  **$K_T$**  and  **$K_H$** .

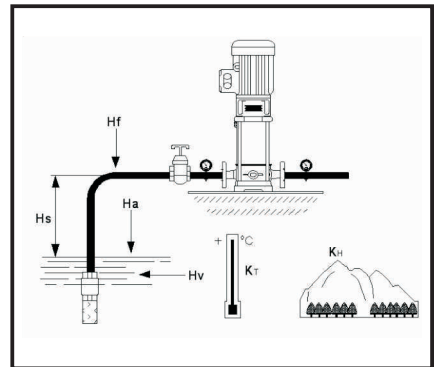

**NPSHA** **NPSHR**: Pump running will be fine.

**NPSHA** < **NPSHR**: The pump will be dry running or cavitating.

<b>T (°C)</b>	20	30	40	50	60	70	80	90	100	110	120
<b>K<sub>r</sub> (m)</b>	0.2	0.4	0.8	1.3	2.2	3.3	5	7.4	11	15	22

<b>H (m)</b>	0	500	1000	1500	2000	2500	3000
<b>K<sub>H</sub> (m)</b>	0	0.55	1.1	1.65	2.2	2.75	0

### 3.3 MINIMUM NOMINAL FLOW RATE



**Do not run the pump against a closed discharge valve for longer than a few seconds.**

- To prevent overheating of the internal pump components, the pump should not be used at flows below the minimum flow rate.
- The curve below shows the minimum flow rate as a percentage of the nominal flow rate in relation to the liquid temperature.

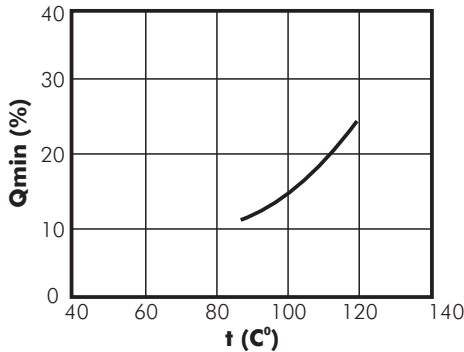

### 3.4 NUMBER OF STARTS PER HOUR

- Motors up to and including 4 kW: Maximum 100 times per hour.
- Motors of 5.5 kW and up: Maximum 40 times per hour.

### 3.5 MAXIMUM OPERATING PRESSURE

Stages	Maximum Operating Pressure	Stages	Maximum Inlet Pressures
<b>DI/DIN1</b>			
2-36	25 bar	2-36	10 bar
<b>DI/DIN3</b>			
2-36	25 bar	2-29	10 bar
		31-36	15 bar
<b>DI/DIN5</b>			
2-36	25 bar	2-16	10 bar
		18-36	15 bar
<b>DI/DIN10</b>			
1-16	16 bar	1-6	8 bar
17-22	25 bar	7-22	10 bar
<b>DI/DIN15</b>			
1-10	16 bar	1-3	8 bar
12-17	25 bar	4-17	10 bar
<b>DI/DIN20</b>			
1-10	16 bar	1-3	8 bar
12-17	25bar	4-17	10 bar
<b>DI/DIN32</b>			
1-7	16 bar	1-4	4 bar
8-14	30 bar	5-10	10 bar
		11-14	15 bar
<b>DI/DIN45</b>			
1-5	16 bar	1-2	4 bar
6-11	30 bar	3-5	10 bar
12-13	33 bar	6-13	15 bar
<b>DI/DIN64</b>			
1-5	16 bar	1-2	4 bar
6-8	30 bar	2-4	10 bar
		4-8	15 bar
<b>DI/DIN90</b>			
1-4	16 bar	1-1	4 bar
5-6	30 bar	2-3	10 bar
		3-6	15 bar
<b>DI/DIN120</b>			
1-7	30 bar	1-2	10 bar
		2-5	15 bar
		6-7	20 bar
<b>DI/DIN150</b>			
1-6	30 bar	1-1	10 bar
		2-4	15 bar
		5-6	20 bar

## 4. INSTALLATION

Always refer to the local or national regulations and codes relating to the selection of the installation site, the water and power connections, etc.

- Pumps should be installed in a protected environment, not exposed to inclement weather. Make sure that there are no obstructions to prevent proper motor cooling.
- Pumps must be secured to a solid foundation by bolts through the holes in the flange or base plate.
- When positioning and installing the pump, follow the installation advice below in order to avoid pump damage.

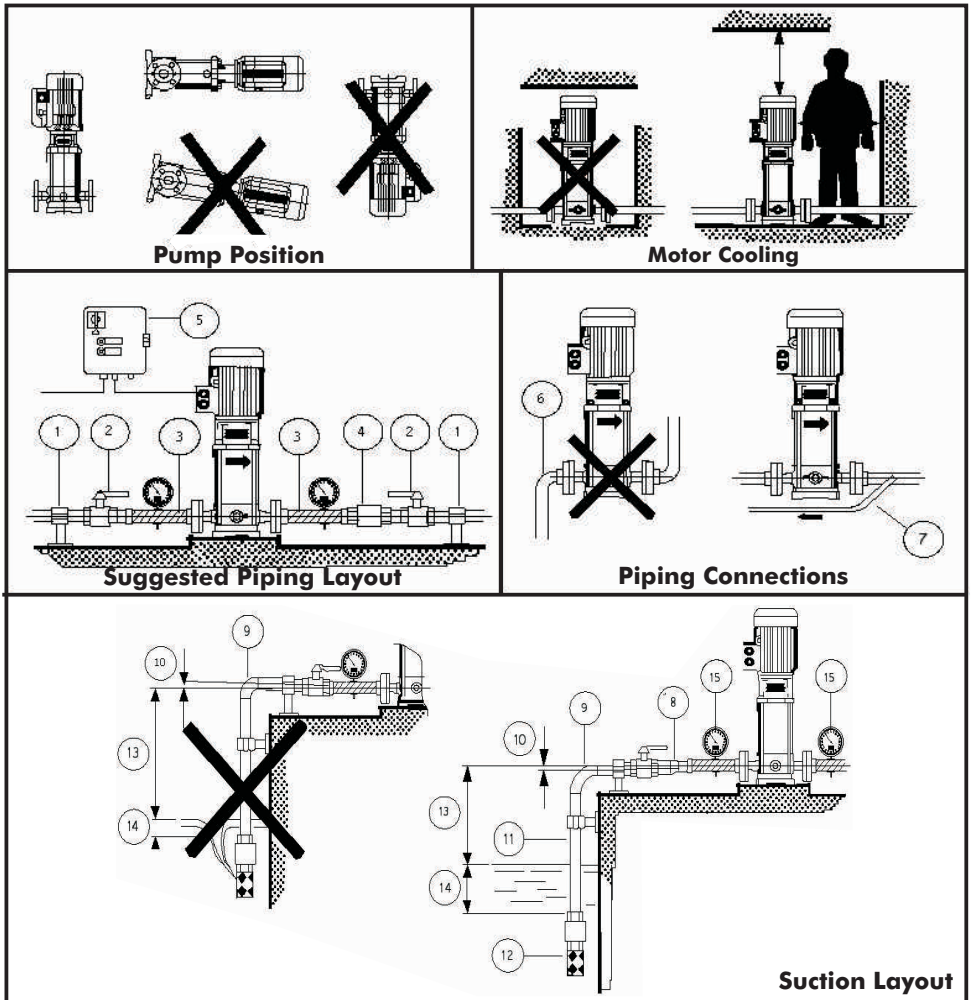



Position	Description
1	Pipe support: Support piping system properly to avoid stresses on connections.
2	On-off valves: Install on-off valves for easy access- before the pump intake and after the pump discharge.
3	Use flexible piping on both input and output sides of the pump to reduce vibration and transmission of noise.
4	Check valves will prevent return flow of pumped liquid when pump is stopped, reducing the danger of pump damage
5	Control Panel: Use high quality components. Make sure that the panel conforms to local standards and regulations
6	Do not place elbows next to the pump intake and discharge
7	If pump needs to be operated in a situation that will result in cycling install a bypass line to avoid damaging the pumping system
8	If it is necessary to increase the diameter of the suction pipe, place an eccentric reducer between the check valve and the flexible pipe section
9	Using elbows will increase the flow resistance. Wide bends will result in lesser flow resistance
10	The piping must have a level or positive gradient to prevent the formation of air pockets
11	Diameter of the suction pipe should be bigger than the diameter of the pumps suction port
12	Use a foot valve in case of negative suction head
13	Ensure suction lift is within limits . As a rule suction lift should be minimised
14	Place the intake of the suction pipe so that the intake is always submerged to prevent entry of air
15	Install a compound gauge at the pump suction and a pressure gauge at the pump discharge

## 5. ELECTRICAL CONNECTIONS



***The installer is responsible for making electrical connections to the mains supply in compliance with relevant local regulations. Ensure that a professional electrician carries out the electrical connections and that the following guidelines are followed***

- All electrical connection should be in accordance with the local regulations and made by a qualified electrician .
- Make sure that the supply voltage, frequency and phase supply are suitable for the motor used.
- Before proceeding, make sure that all the connections are grounded and well insulated .
- Overload protection should be provided.
- To connect, proceed as shown on the inside of the terminal board cover.

- The terminal box can be turned to four positions.
- Check the direction of rotation (Three-phase motor only) .
- Make sure that the controls are properly grounded.
- To avoid the possibility of dry running, the installation of dry running protection is strongly recommended.

## 6. START UP



***Dry running can damage the pump bearing and shaft seal.***

The pump and suction pipe should be filled with the liquid to be pumped before start-up to prevent dry running at start-up.

- Close the discharge valve.
- Fill pump casing with water through the priming plug. (See Pump Priming)
- Start the pump and check the direction of rotation of the motor (Three-Phase motors).
- Slowly open the discharge valve. The pump must run smoothly and noiselessly. If not it may be necessary to re-prime the pump.
- Check the current drawn by the motor. If necessary, adjust the setting of the thermal relay.
- Open the air release valve on the top of the pump outlet and bleed any trapped air. (See Air Bleeding)
- For DI/DIN1, 3 & 5 pumps, it is advisable to open the bypass valve during start-up. The bypass valve connects the suction and discharge sides of the pump, thus making the filling procedure easier. When the operation is stable, the bypass valve can be closed.
- If the pumped liquids contains air, it is advisable to leave the bypass valve open if the operating pressure is lower than 6 bar.
- If the operating pressure constantly exceeds 6 bar, the bypass valve must be closed. Otherwise the material at the opening will be worn because of the high liquid velocity.

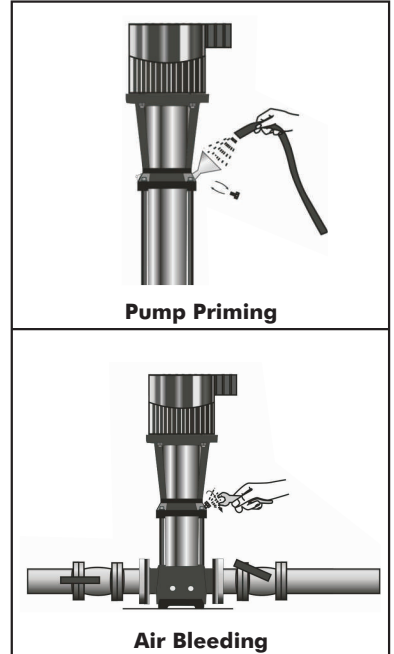

## 7. MAINTENANCE



***Before starting maintenance work on the pump, the motor, or other parts of the system, make sure that the power supply has been switched off.***

- The pump does not have a recommended maintenance schedule. However, periodically, recommended monthly the installation should be visually checked and pump operation monitored for leaks, noise or vibration. Also the electrical installation should be inspected and the pump operating current checked. Any operational defects should be rectified accordingly.
- If the motor is fitted with grease nipples, then the motor should be lubricated with a high temperature lithium-based grease. If not, then the motor does not require regular maintenance.
- If the pump and motor are used infrequently with long intervals of non-operation, then it is recommend that the motor be greased.

# 8. TROUBLE SHOOTING

## PROBLEM

## POSSIBLE CAUSE

## SOLUTION

Pump does not run when the motor starter is activated

Supply failure or no power supply

Check connections or restart the power supply

Main contacts in motor starter are not making contact or the motor coils are defective

Reconnect or replace contacts or magnetic coil

Pump or auxiliary circuits protection fuses blown

Replace fuses

Pump or piping system may be obstructed

Clean the obstruction and restart pump

Motor has burst out

Replace or rewind the motor

Motor protector or thermal relay has tripped out

Reset the motor or thermal protector

Tripping of dry running protection

Check the water level in the tank or the water system pressure. If everything is in order, check the protection device and its connection cables

Starter overload trips immediately pump switched on

Overload setting is too low

Set the motor starter correctly

The cable connection is loose or faulty

Fasten or replace the cable connection

Pump is jammed

Check and rectify

Contacts in overload are faulty

Replace motor starter contacts

The motor winding is defective

Replace or rewind the motor

Low voltage (especially at peak time)

Check the power supply

The system's general protection cuts in

Short circuit

Check electrical system

Pump starts but after a short time, the thermal overload trips out or the fuses blow

The voltage is not within the motors operating limits

Check the operating conditions of the pump

The control panel is situated in an excessively heated area or is exposed to direct sunlight

Protect the control panel from heat sources and direct sunlight

A phase in the power supply is missing

Check the power supply

## PROBLEM

## POSSIBLE CAUSE

## SOLUTION

The pump starts up but after a period of time, the thermal overload trips

Worn motor bearings causing motor to overheat

Replace motor bearings

The pumps delivery rate is higher than the specified rate on the pump nameplate

Partially close the on-off valve located discharge side until the delivery rate returns to within the specified limits

There are obstructions inside the pump or pumping systems

Disassemble and clean the pump and piping

Less viscous liquids may cause the motor to work too hard and overload the motor, causing the motor to overheat

Check the actual power requirements based on characteristics of the liquid being pumped and replace the motor accordingly

Pump runs but no water delivered

Pump is not primed with liquid

Fill the pump with the liquid to be pumped

The pump, suction or discharge pipes are blocked by solids in the liquid being pumped

Clean the pump, suction or discharge pipe

The foot or check valve is blocked or has failed

Replace the foot or check valve

The suction pipe leaks

Repair or replace the suction pipe

Air is in the suction pipe or pump

Removed trapped air from the system

Motor operating in wrong direction (three-phase motor)

Change the direction of rotation of the motor by reversing motor connections

The pump capacity is not constant

The pump draws in air or the inlet pressure is too low

Improve the suction conditions

The pump or the suction side of the piping system partly blocked by foreign bodies

Clean the pump or suction pipe

The pump rotates in the wrong direction when switched off

The foot or the check valve has failed

Check and replace check valve

Leakage in the suction pipe

Repair or replace the suction pipe

## 9. TERMS OF WARRANTY

### i) General Liability

- In lieu of any warranty, condition or liability implied by law, the liability of Davis & Shirliff (hereafter called the Company) in respect of any defect or failure of equipment supplied **is limited to making good by replacement or repair** (at the Company's discretion) defects which under proper use appear therein and arise solely from faulty design, materials or workmanship within a specified period. This period commences **immediately after the equipment has been delivered to the customer** and at its termination all liability ceases. Also the warranty period will be assessed **on the basis of the date that the Company is informed of the failure.**
- This warranty applies solely to equipment supplied and **no claim for consequential damages**, however arising, will be entertained. Also the warranty specifically excludes defects caused by fair wear and tear, the effects of careless handling, lack of maintenance, faulty installation, incompetence on the part of the equipment user, Acts of God or any other cause beyond the Company's reasonable control. Also, any repair or attempt at repair carried out by any other party **invalidates all warranties.**

### ii) Standard Warranty

If equipment failure occurs in the normal course of service having been competently installed and when operating within its specified duty limits warranty will be provided as follows:-

- **Up to two years - The item will be replaced or repaired at no charge.**
- **Over two years, less than three years - The item will be replaced or repaired at a cost to the customer of 50% of the Davis & Shirliff market price.**

The warranty on equipment supplied or installed by others is conditional upon the defective unit **being promptly returned free to a Davis & Shirliff office** and collected thereafter when repaired. No element of site repair is included in the warranty and any site attendance costs will be payable in full at standard chargeout rates. Also proof of purchase including the purchase invoice must be provided for a warranty claim to be considered.



**DAYLIFF** is a brand of **Davis & Shirtliff**

for enquiries contact

**Davis & Shirtliff, Ltd.**

P.O. Box 41762 - 00100, Nairobi, Kenya

Tel: 6968000/ 0711 079 000

or visit

**[www.dayliff.com](http://www.dayliff.com)**

for details of the nearest branch or stockist