

GRUNDFOS®

MADE IN DENMARK



DATA SHEET

Submersible Drainage Pumps

DWK



DWK 50.15

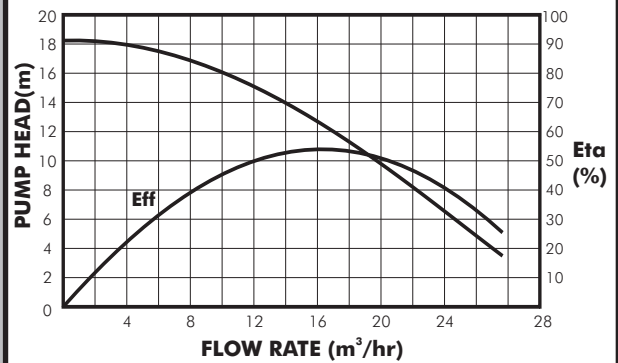

DWK 80.22

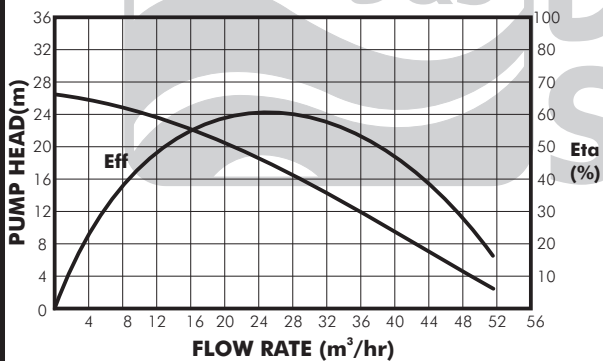

DWK 80.37

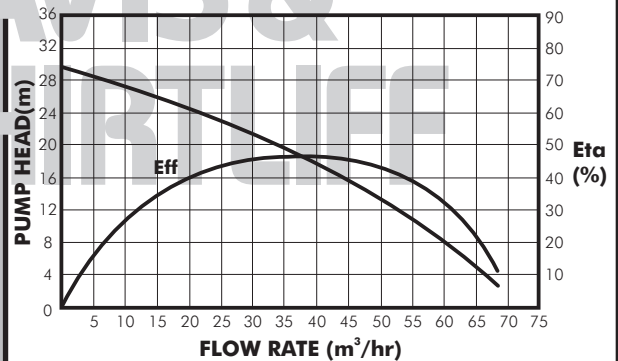

DWK 100.55

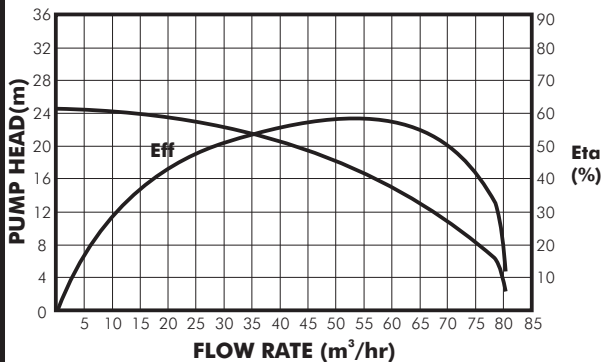

DWK 150.110

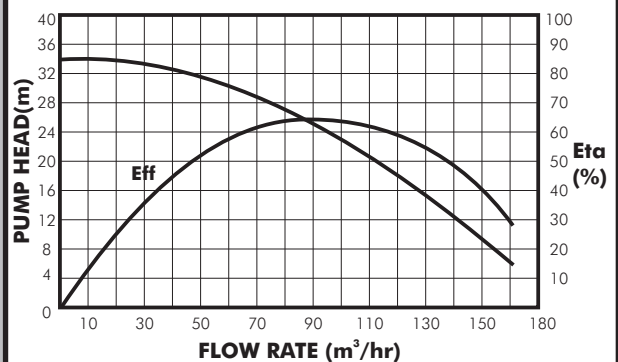

Pump

GRUNDFOS DWK waste water pumps are specially designed for heavy-duty drainage and de-watering requirements in applications including construction sites, mines, quarries, etc. All pumps are fitted with semi-open impellers for efficiency and effective solids passing performance. They are of exceptionally robust design and are manufactured using the highest quality materials to ensure reliability in the harshest operating conditions. Also the pumps' slim design suits both temporary and permanent installations and makes them easy to handle, transportable and simple to install.

Materials of construction are high chrome stainless steel for the impellers and cast iron for the pump casings and other hydraulic components. Heavy duty dual mechanical seals are fitted and all pumps are supplied with 10m of cable.

The extensive GRUNDFOS DWK pump range covers a wide selection of duties, the five models details being standard stock lines. Other models and specifications are available to special order to suit different pumping applications.

Motor

Pumps are fitted with integral squired cage two pole induction motors designed for continuous operation provided the pump is fully submerged in water. A bimetallic thermal contact switch is incorporated in the windings for additional protection, though all models should be provided with a remote starter with overload protection

Insulation Class: F (155°C) **Voltage:** 3 x 415V **Speed:** 2900rpm **Enclosure Class:** IP68

Operating Conditions

Pumped Liquid: Thin chemically non-aggressive liquids containing solids up to the specified particle size.

Temperature Range: 0°C-40°C

pH range: 4-10

Max Immersion Depth: 25m

DATA

Model	kW	Starter Type	Operating Current (A)	Dimensions (mm)				Max. Particle Size (mm)	Weight (Kgs)
				A	B	C	Outlet		
DWK 50.15	1.5	DOL	3.6	478	202	231	50	6	41
DWK 80.22	2.2	DOL	5.1	498	202	231	80	6	45
DWK 80.37	3.7	DOL	8.2	680	234	286	80	10	81
DWK 100.55	5.5	DOL	11.9	709	302	353	100	13	110
DWK 150.110	11	YD	23	754	302	353	150	13	190

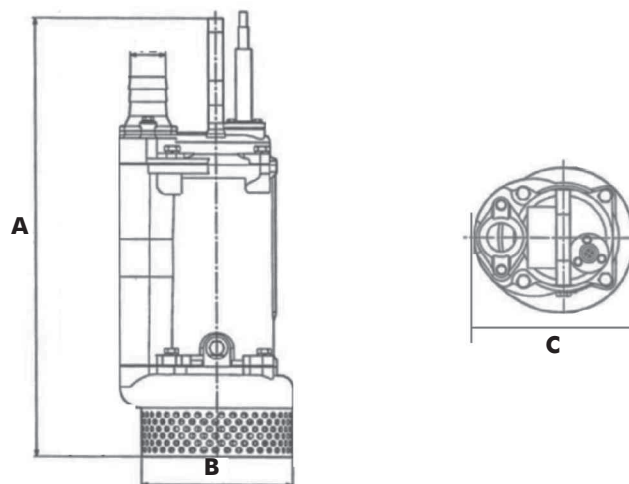

© Davis & Shirliff 2014. Contents herein are not warranted. The right is reserved to amend specifications without notice. www.davisandshirliff.com

GR250A-07/12

KENYA NAIROBI - HEAD OFFICE TEL: (+254 20) 6968 000 headoffice@dayliff.com NAIROBI - WESTLANDS TEL: (+254 20) 44480116, westlands@dayliff.com NAIROBI - DOWNTOWN TEL: (+254 20) 340102 downtown@dayliff.com NAIROBI - KAREN TEL: (+254 20) 3883513 karen@dayliff.com THIKA TEL: (+254 67) 20084/5 thika@dayliff.com ELDORET TEL: (+254 53) 2061306 eldoret@dayliff.com	NAKURU TEL: (+254 51) 2213248 nakuroffice@dayliff.com KISUMU TEL: (+254 57) 2024763 ksmoffice@dayliff.com KISII TEL: (+254 58) 2030949 ksil@dayliff.com NAIVASHA TEL: (+254 50) 2030510 naivasha@dayliff.com MACHAKOS TEL: (+254 40) 2021668 naivasha@dayliff.com MERU TEL: (+254 64) 3131033 meru@dayliff.com	GARISSA TEL: (+254 46) 2102620 garissa@dayliff.com KENYA COAST MOMBASA - Main Office TEL: (+254 20) 2040432 d&smasa@dayliff.com MALINDI TEL: (+254 42) 2120425 mlidoffice@dayliff.com DIANI TEL: (+254 40) 3202181 dianioffice@dayliff.com LAMU TEL: (+254 20) 2651052/56 lamu@dayliff.com	NYALI TEL: (+254 20) 2443357 d&sn@nyali.dayliff.com VOI TEL: (+254 20) 2028284 voi@dayliff.com ETHIOPIA ADDIS ABABA TEL: (+251 11) 5159341/44 d&sethiopia@dayliff.com RWANDA KIGALI TEL: (+250 252) 504039 rwoffice@dayliff.com	UGANDA KAMPALA - Main Office TEL: (+256 414) 346337/8 d&skampala@dayliff.com KAMPALA - NAKESERO TEL: (+256 392) 734633 d&snakasero@dayliff.com GULU TEL: (+256 471) 433041 d&sgulu@dayliff.com MBARARA TEL: (+256 753) 940 080 d&smbarara@dayliff.com	TANZANIA DAR ES SALAAM - Main Office TEL: (+255 22) 2112515/6 d&sdaressalaam@dayliff.com DAR ES SALAAM - KARIAKOO TEL: (+255 22) 2184867 d&skariakoo@dayliff.com ARUSHA TEL: (+255 27) 2547317/8 arusha@dayliff.com ZANZIBAR TEL: (+255 24) 2234660/1 zanzibar@dayliff.com MWANZA TEL: (+255 28) 2541971/2 d&smwanza@dayliff.com	ZAMBIA LUSAKA - Main Office TEL: (+260 211) 288010/1 d&slusaka@dayliff.com NDOLA TEL: (+260 212) 610936/7 d&sndola@dayliff.com KITWE TEL: (+260 212) 221747/67 d&skitwe@dayliff.com LIVINGSTONE TEL: (+260 213) 320002/234 d&slivingstone@dayliff.com SOUTH SUDAN JUBA TEL: (+211 956) 397 070 juba@dayliff.com
---	---	---	--	--	---	--