

## DATA SHEET

Sewage  
Lifting Unit

## SOLOLIFT2

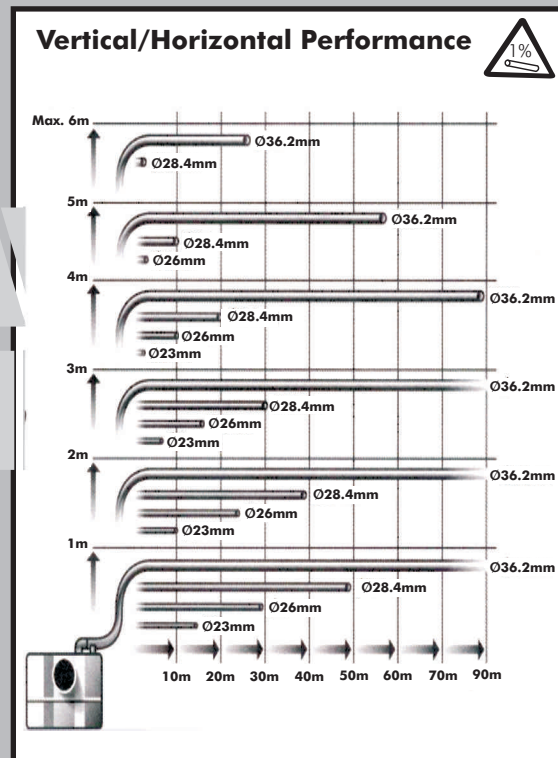
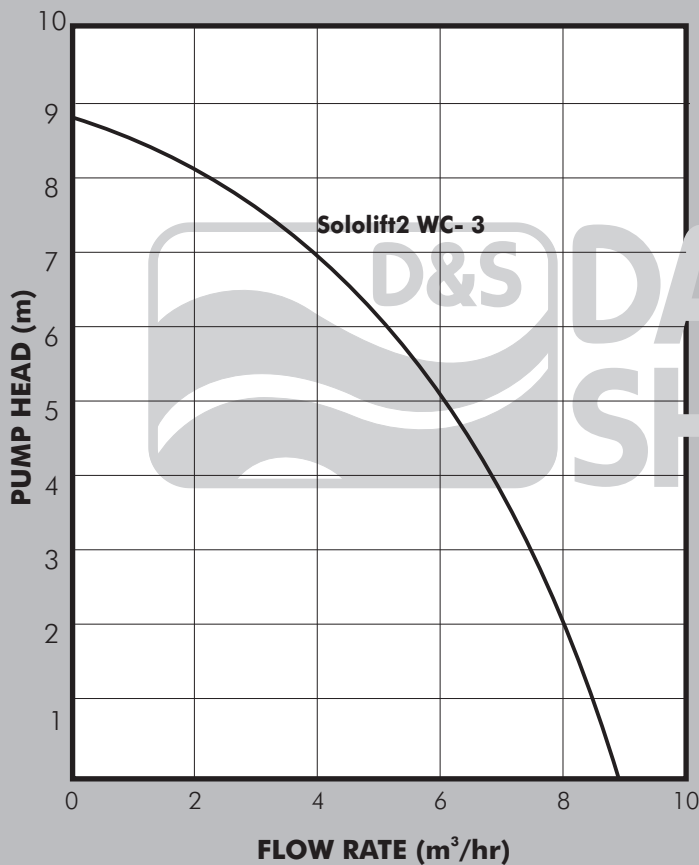
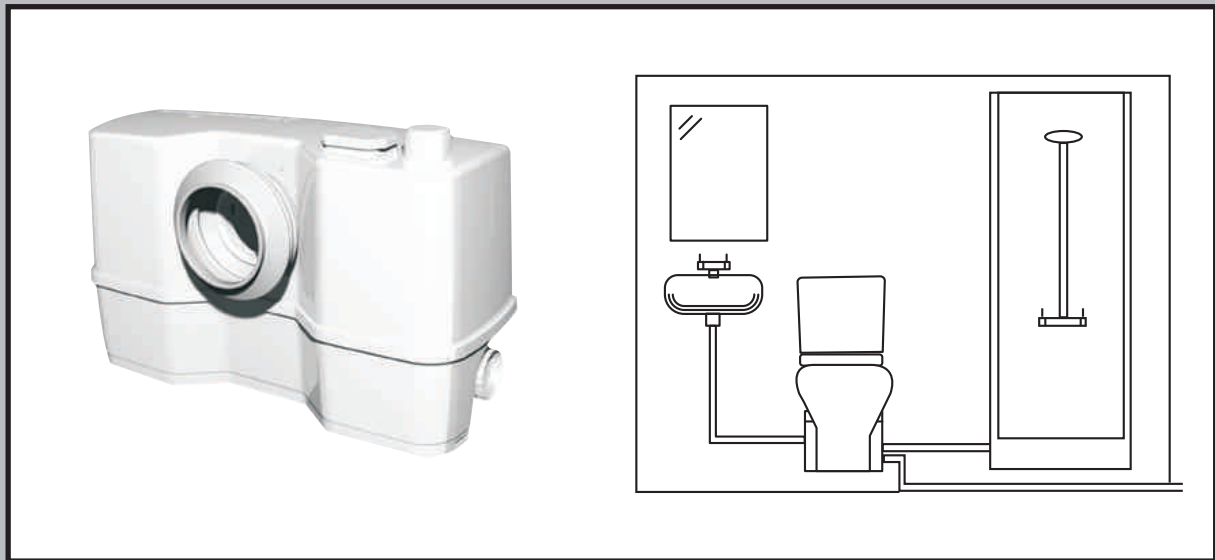

## UNIT DESCRIPTION

The GRUNDFOS Sololift2 is a unique product designed for the collection and discharge of waste from a WC, washbasin, shower and bidet where site conditions prevent direct connection to gravity sewage system. This can arise due to the installation being below the sewer level or remoteness making direct drainage impractical. The unit consists of a collector tank directly connected to the WC outlet which contains a highly effective steel grinder pump that macerates toilet waste so it can easily pass through small bore water pipes. Particular features include:

- Self cleaning design with sloping bottom keeps grinder and tank free from sedimentation.
- Built in charcoal filter eliminates odours.
- Lift out motor and pump for quick and clean repairs and service.
- High torque pump motor with special winding and shaft technology for improved maceration efficiency.

The unit is supplied with all necessary installation fittings and is provided with three inlets so is suitable for connection to all bathroom facilities as well as a 'P-trap' type toilet making installing discreet and simple

## PUMP

The integral cutter pump is controlled automatically by means of a pneumatically operated level switch. It is provided with in-built thermal protection and can be connected directly to the main power supply through a 10amps MCB or fuse.

**Power Consumption:** 620W

**Voltage:** 1 x 240V, 50Hz

**Operating Current:** 3A

**Insulation:** F

**Enclosure Class:** IP24

## OPERATING CONDITIONS

**Pumped Liquid:** Sewage water containing toilet paper and faeces, though not sanitary articles or wastewater containing fat.

**Max. Fluid Temperature Range:** +50°C

**Max. Fluid Volume:** 9Litres

**pH Range:** 4-10

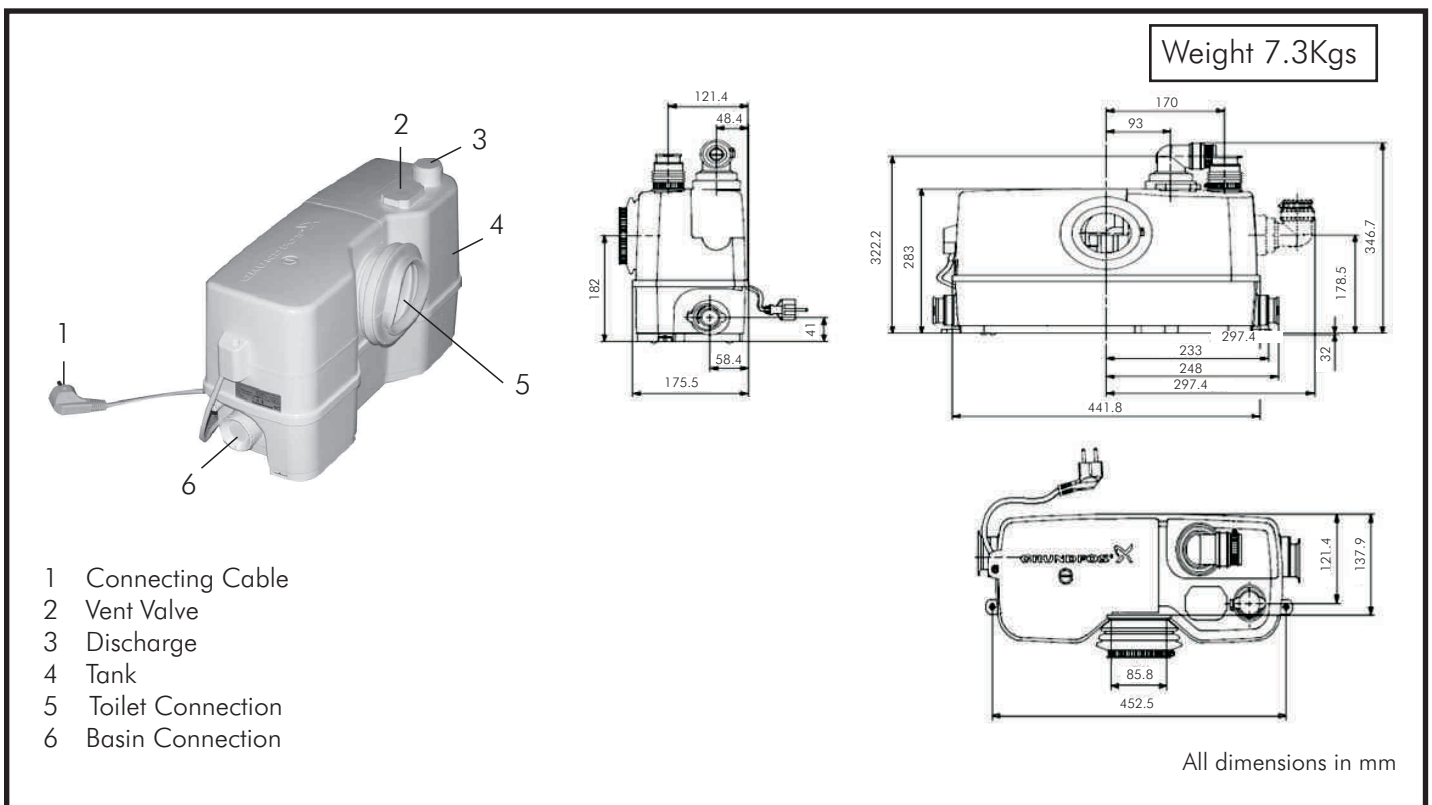

<p><b>KENYA</b>  <b>NAIROBI - HEAD OFFICE</b>                      TEL: (+254 20) 6968 000                      headoffice@dayliff.com  <b>NAIROBI - WESTLANDS</b>                      TEL: (+254 20) 44480116,                      westlands@dayliff.com  <b>NAIROBI - DOWNTOWN</b>                      TEL: (+254 20) 340102                      downtown@dayliff.com  <b>NAIROBI - KAREN</b>                      TEL: (+254 20) 3883513                      karen@dayliff.com  <b>THIKA</b>                      TEL: (+254 67) 20084/5                      thika@dayliff.com  <b>ELDORET</b>                      TEL: (+254 53) 2061306                      eldoret@dayliff.com</p>	<p><b>NAKURU</b>                      TEL: (+254 51) 2213248                      nakuruoffice@dayliff.com  <b>KISUMU</b>                      TEL: (+254 57) 2024763                      ksmoffice@dayliff.com  <b>KISII</b>                      TEL: (+254 58) 2030949                      ksil@dayliff.com  <b>NAIVASHA</b>                      TEL: (+254 50) 2030510                      naivasha@dayliff.com  <b>MACHAKOS</b>                      TEL: (+254 40) 2021668                      naivasha@dayliff.com  <b>MERU</b>                      TEL: (+254 64) 3131033                      meru@dayliff.com</p>	<p><b>GARISSA</b>                      TEL: (+254 46) 2102620                      garissa@dayliff.com  <b>KENYA COAST</b>  <b>MOMBASA - Main Office</b>                      TEL: (+254 20) 2040432                      d&amp;smasa@dayliff.com  <b>MALINDI</b>                      TEL: (+254 42) 2120425                      mldoffice@dayliff.com  <b>DIANI</b>                      TEL: (+254 40) 3202181                      dianioffice@dayliff.com  <b>LAMU</b>                      TEL: (+254 20) 2651052/56                      lamu@dayliff.com</p>	<p><b>NYALI</b>                      TEL: (+254 20) 2443357                      d&amp;snlyali.dayliff.com  <b>VOI</b>                      TEL: (+254 20) 2028284                      voi@dayliff.com  <b>ETHIOPIA</b>  <b>ADDIS ABABA</b>                      TEL: (+251 11) 5159341/44                      d&amp;sethiopia@dayliff.com  <b>RWANDA</b>  <b>KIGALI</b>                      TEL: (+250 252) 504039                      rwoffice@dayliff.com</p>	<p><b>UGANDA</b>  <b>KAMPALA - Main Office</b>                      TEL: (+256 414) 346337/8                      d&amp;skampala@dayliff.com  <b>KAMPALA - NAKESERO</b>                      TEL: (+256 392) 734633                      d&amp;snakaseroo@dayliff.com  <b>GULU</b>                      TEL: (+256 471) 433041                      d&amp;sgulu@dayliff.com  <b>MBARARA</b>                      TEL: (+256 753) 940 080                      d&amp;smbarara@dayliff.com</p>	<p><b>TANZANIA</b>  <b>DAR ES SALAAM - Main Office</b>                      TEL: (+255 22) 2112515/6                      d&amp;sdarressalaam@dayliff.com  <b>DAR ES SALAAM - KARIAKOO</b>                      TEL: (+255 22) 2184867                      d&amp;skariakoo@dayliff.com  <b>ARUSHA</b>                      TEL: (+255 27) 2547317/8                      arusha@dayliff.com  <b>ZANZIBAR</b>                      TEL: (+255 24) 2234660/1                      zanzibar@dayliff.com  <b>MWANZA</b>                      TEL: (+255 28) 2541971/2                      d&amp;smwanza@dayliff.com</p>	<p><b>ZAMBIA</b>  <b>LUSAKA - Main Office</b>                      TEL: (+260 211) 288010/1                      d&amp;slusaka@dayliff.com  <b>NDOLA</b>                      TEL: (+260 212) 610936/7                      d&amp;sndola@dayliff.com  <b>KITWE</b>                      TEL: (+260 212) 221747/67                      d&amp;skitwe@dayliff.com  <b>LIVINGSTONE</b>                      TEL: (+260 213) 320002/234                      d&amp;slivingstone@dayliff.com  <b>SOUTH SUDAN</b>  <b>JUBA</b>                      TEL: (+211 956) 397 070                      juba@dayliff.com</p>
--	---	---	--	--	---	---