

DAVEY

DATA SHEET

Pump Controllers

TORRIUM 2



Torrium2 is a technology leading on-demand pump controller that includes many unique features in a compact, robust, easy to install unit. Control is effected through a corrosion and scale resistant stainless steel plate that senses flow and pressure in the water stream, assisted by an in-built spring loaded pressure reservoir which reduces cycling. These signals are transmitted to an intelligent microprocessor that monitors and adapts pump operation according to demand and environmental conditions providing the following control functions:-

- System cut-out at low flow and cut-in at 80% of the cut-out pressure providing constant, even pressure flow.
- Dry run protection including sequential automatic re-start function.
- Water leakage detection which minimises pump cycling.
- High current shutdown and low voltage indication.
- High water temperature protection and automatic restart below 60°C.
- LED operation and fault indicator providing simple interpretation of operating status.
- Built in sacrificial varistor to protect against electrical power surges.
- Selectable vertical and horizontal delivery outlets.

Torrium2 is manufactured entirely from corrosion proof reinforced nylon. Its unique features and exceptionally robust design offers many advantages over alternative controllers integrating all functions necessary for small pump control into one compact unit that eliminates the need for any other protection. Its simplicity, reliability and effectiveness make it the most sophisticated controller available for all small flow pumped water supply installations.

INSTALLATION

Torrium2 is designed to screw directly on to the delivery outlet of the pump and accommodate the full delivery flow. It can be fitted to both dry booster pumps with positive or negative suction and to submersible pumps with closed head pressures less than 4.5Bar and both vertical and horizontal delivery options are available.

HYDRAULIC PRESSURE LOSS

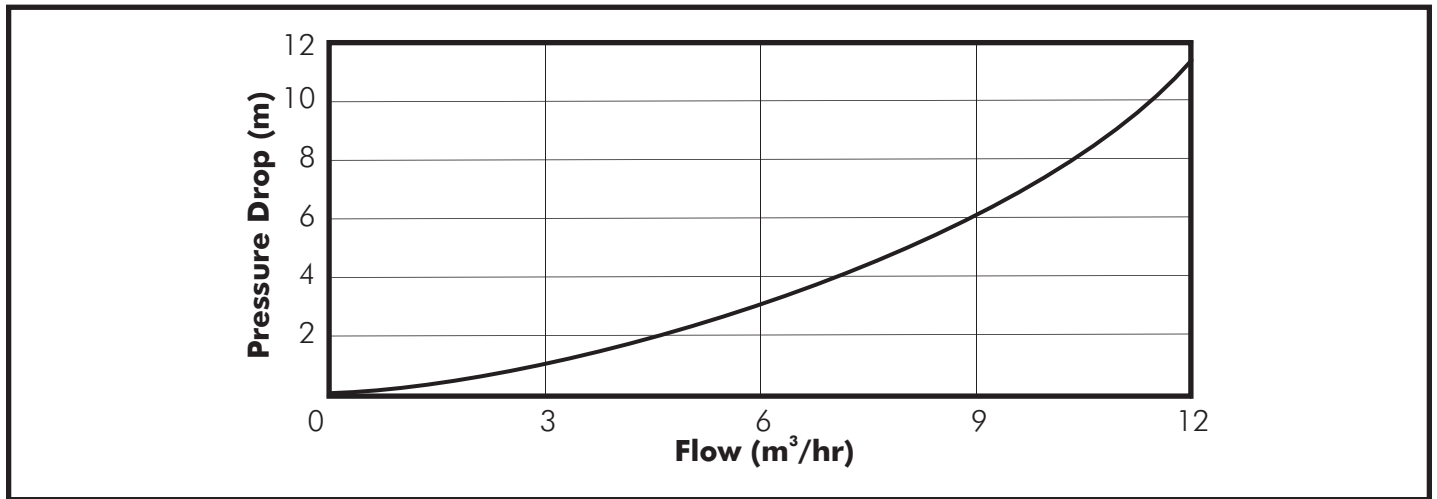

OPERATING CONDITIONS

Pumped Liquid: Thin, clean chemically non-aggressive liquids, containing no solids or fibres

Power Supply: 240V, 50Hz

Enclosure Class: IP56

Operating Water Temperature Range: +1°C to +70°C

Max. Ambient Temperature: +50°C

Max. Rated Flow: 12m³/hr

Max. System Pressure: 7 Bar

Pump Shut Off Pressure Range: 1.5 - 4.5Bar

Pump Shut Off Flow : 2 l/min

Pump Cut In Pressure: 80% Shut off Pressure

Max. Motor Size : 1.8kW

Max. Load Current: 10 Amps

DIMENSIONS AND WEIGHT

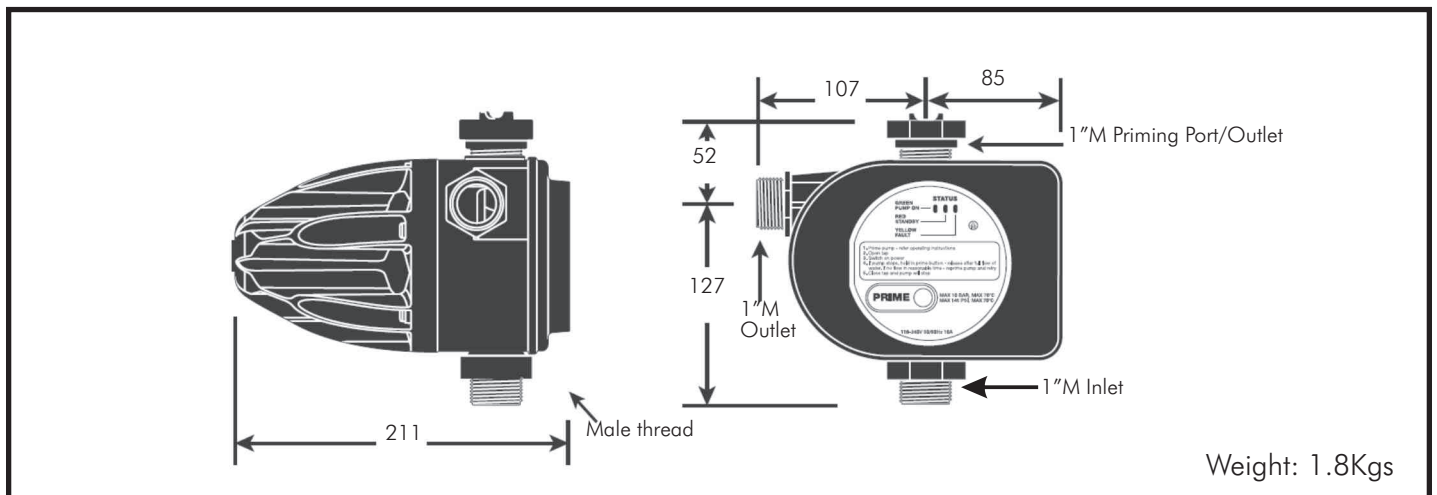

© Davis & Shirtliff 2014. Contents herein are not warranted. The right is reserved to amend specifications without notice. www.davisandshirtliff.com

DV65B-01/11

KENYA

NAIROBI - HEAD OFFICE

TEL: (+254 20) 6968 000

headoffice@dayliff.com

NAIROBI - WESTLANDS

TEL: (+254 20) 44480116,

westlands@dayliff.com

NAIROBI - DOWNTOWN

TEL: (+254 20) 340102

downtown@dayliff.com

NAIROBI - KAREN

TEL: (+254 20) 3883513

karen@dayliff.com

THIKA

TEL: (+254 67) 20084/5

thika@dayliff.com

ELDORET

TEL: (+254 53) 2061306

eldoret@dayliff.com

NAKURU

TEL: (+254 51) 2213248

nakuroffice@dayliff.com

KISUMU

TEL: (+254 57) 2024763

ksumoffice@dayliff.com

KISII

TEL: (+254 58) 2030949

kisii@dayliff.com

NAIVASHA

TEL: (+254 50) 2030510

naivasha@dayliff.com

MACHAKOS

TEL: (+254 40) 2021668

machakos@dayliff.com

MERU

TEL: (+254 64) 3131033

meru@dayliff.com

GARISSA

TEL: (+254 46) 2102620

garissa@dayliff.com

KENYA COAST

MOMBASA - Main Office

TEL: (+254 20) 2040432

dsmbsa@dayliff.com

MALINDI

TEL: (+254 42) 2120425

maloffice@dayliff.com

DIANI

TEL: (+254 40) 3202181

dianioffice@dayliff.com

LAMU

TEL: (+254 20) 265105256

lamu@dayliff.com

NYALI

TEL: (+254 20) 2443357

d8s@nyali.dayliff.com

VOI

TEL: (+254 20) 2028284

voi@dayliff.com

ETHIOPIA

ADDIS ABABA

TEL: (+251 11) 515934144

d8sethiopia@dayliff.com

RWANDA

KIGALI

TEL: (+250 252) 504039

rwoffice@dayliff.com

UGANDA

KAMPALA - Main Office

TEL: (+256 414) 3463378

d8skampala@dayliff.com

KAMPALA - NAKESERO

TEL: (+256 392) 734633

d8snakasero@dayliff.com

GULU

TEL: (+256 471) 433041

d8gulu@dayliff.com

MBARARA

TEL: (+256 753) 940 080

d8smbarara@dayliff.com

TANZANIA

DAR ES SALAAM - Main Office

TEL: (+255 212) 21125156

d8sdaressalaam@dayliff.com

DAR ES SALAAM - KARIAKOO

TEL: (+255 22) 2184867

d8skariakoo@dayliff.com

ARUSHA

TEL: (+255 27) 25473178

arusha@dayliff.com

ZANZIBAR

TEL: (+255 24) 2234660/1

zanzibar@dayliff.com

MWANZA

TEL: (+255 28) 2541971/2

d8smanza@dayliff.com

ZAMBIA

LUSAKA - Main Office

TEL: (+260 211) 288010/1

d8slusaka@dayliff.com

NDOLA

TEL: (+260 212) 610936/7

d8sndola@dayliff.com

KITWE

TEL: (+260 212) 221747/67

d8skitwe@dayliff.com

LIVINGSTONE

TEL: (+260 213) 320002/234

d8slivingstone@dayliff.com

SOUTH SUDAN

JUBA

TEL: (+211 956) 397 070

juba@dayliff.com