

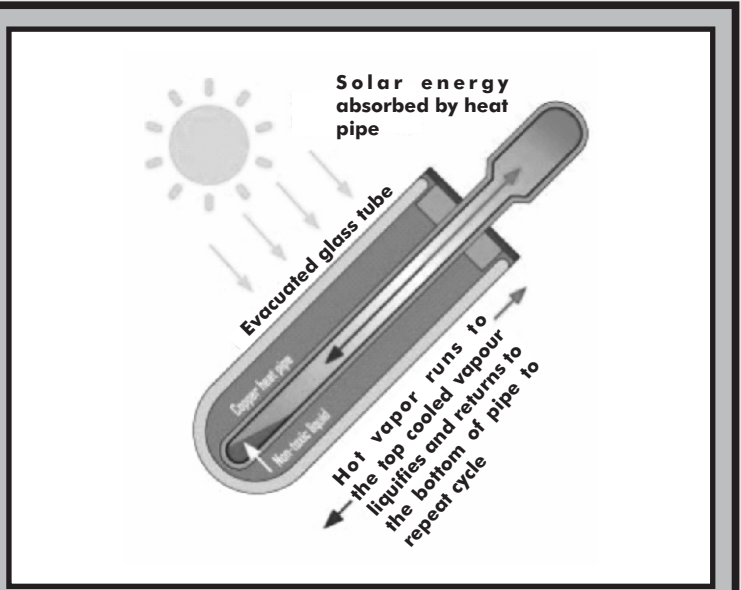

# Ultrasun UVR

## Vacrod Solar Water Heaters



Ultrasun UVR VacRod Solar Hot Water Heaters provide highly effective water heating in small and medium residential applications. They feature a series of glass heat pipes that consist of two sealed concentric glass tubes with a vacuum created in the void between to aid efficient heat transfer. A copper rod is inserted into the inner tube void which projects into a header manifold, the void being filled with water to optimise heat transfer and sealed at its end. The consumption water flows through the manifold and is heated by the projecting copper rod. This water continuously circulates through the storage tank on the thermosyphon principle thus heating the tank contents. The process is extremely effective and has the benefits of being suitable for lightly pressurized systems and also can be used with mineralized water. Particular features of the systems are:-

- Double layered borosilicate glass vacuum tube with clear outer layer and an inner layer specially coated for maximum solar irradiation absorption.
- Storage tank comprising heavy duty stainless steel SU316 inner cylinder with external insulated painted steel casing and fitted with a thermostat controlled electric heating element. The electric heater automatically switches when there is insufficient solar irradiation.
- Aluminium header manifold for heat transfer.
- Anodised aluminium frame.
- Five year guarantee for the tank and heating tubes.

Ultrasun UVR VacRod heaters are highly efficient and effective products designed for various installation conditions including pressurized direct supply and mineralized input water. They are manufactured to the highest standards and will give many years of free hot water and trouble-free operation.

### OPERATING CONDITIONS

**Water Quality:** Water outside the following limits should be appropriately pre-treated, clarity: clear, TDS < 600mg/l, Hardness < 200mg/l CaCO<sub>3</sub>

**Maximum Operating Temperature:** 300°C

**Maximum Operating Pressure:** 6bar

### SPECIFICATIONS

MODEL	UVR 150	UVR 200	UVR 300	
<b>System Tank Capacity (L)</b>	150	200	300	
<b>Typical Household (People)</b>	5	7	10	
<b>No. of Vacuum Tubes</b>	15	20	30	
<b>Effective Area, m<sup>2</sup> (Aperture Area)</b>	1.4	1.9	2.8	
<b>Max. Heat Output/day (kWhrs)</b>	8.3	11.2	16.7	
<b>Min. Heat Output/day (kWhrs)</b>	5.6	7.4	11.2	
<b>Heater Element, kW</b>	2	2	3	
<b>Dimensions, mm</b>	<b>A</b>	1035	1325	1935
	<b>W</b>	1250	1625	2375
<b>Empty Weight, Kgs</b>	52	72	110	
<b>Full Weight, Kgs</b>	202	272	410	

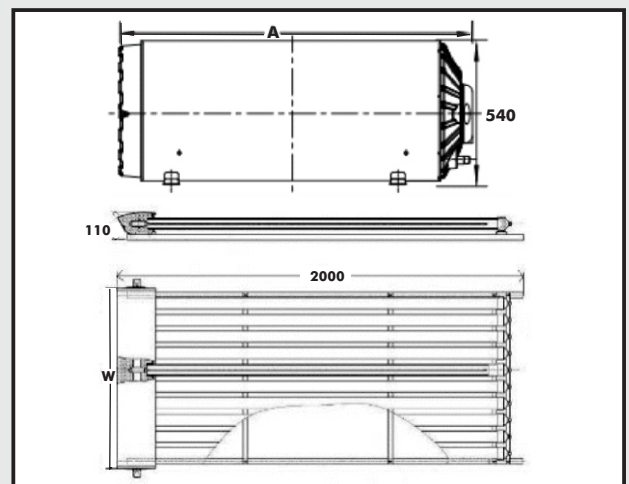

**NOTE:** Maximum heating output is based on average irradiation levels of 6000W/m<sup>2</sup>/day prevailing in September- March and minimum Heating output is based on average irradiation levels of 4000W/m<sup>2</sup>/day prevailing in June/July and are for indicative purposes only.