

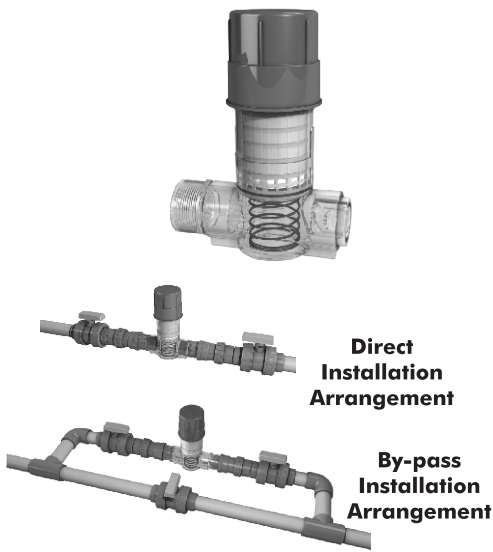

Water Disinfection Systems

KLORMAN INLINE



Klorman is a simple in-line point of use disinfection system that utilizes a compacted calcium hypochlorite chlorine cartridge which releases active chlorine sanitizer into the water flow. Simple adjustment is provided by varying the projection of the cartridge into the water stream to accommodate different flow rates as well as adjustment of water flow and pressure through the unit. Dosage levels vary with site conditions and treatment water chlorine demand, though sufficient dosage is available to ensure adequate water disinfection.

The unit is economical to buy, simple to install, extremely reliable and totally effective and presents the ideal solution for continuous disinfection of household, community, agricultural, sewage and commercial water supplies where constant treatment is required in applications without external power or experienced operators.

Dosage capacity: 500m³ at 1 ppm with no chlorine demand. Capacity varies with flow and installation conditions

Max flow rate: 16m³/hr

Max Operating Pressure: 0.5 to 6 bar (higher pressures are possible in the absence of surge/water hammer)

KLORMAN 2000

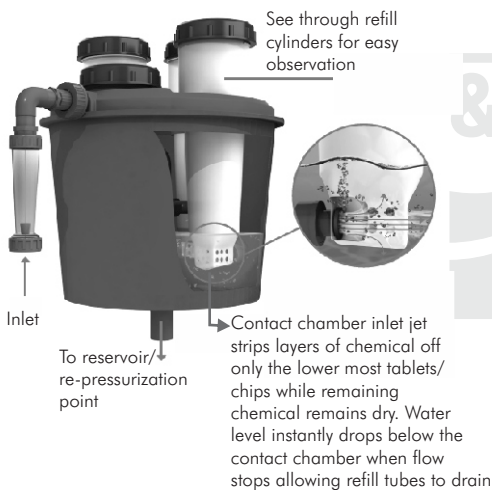

Klorman 2000 is a large capacity disinfection system that works on the simple Klorman principal of releasing active chlorine sanitizer into the passing water flow. Chlorine cartridges in either solid or chip form are suspended in a reservoir through which the untreated water flows in the process being dosed with dissolved chlorine. The units should be connected either inline or a bypass directly before the storage tanks and dosage stops with water flow preventing over-chlorination.

Dosage Capacity: 22 kg of full refill tablets will dose 1 6000m³ at 1 ppm

Maximum Flow Rate through the contact Chamber: 5m³/hr.

Minimum Flow Rate through the contact chamber: 0.6m³/hr.

Chlorine Dosage: 50-350ppm depending on flow rate.

Maximum inlet Pressure: 3 bar

BUCCANEER

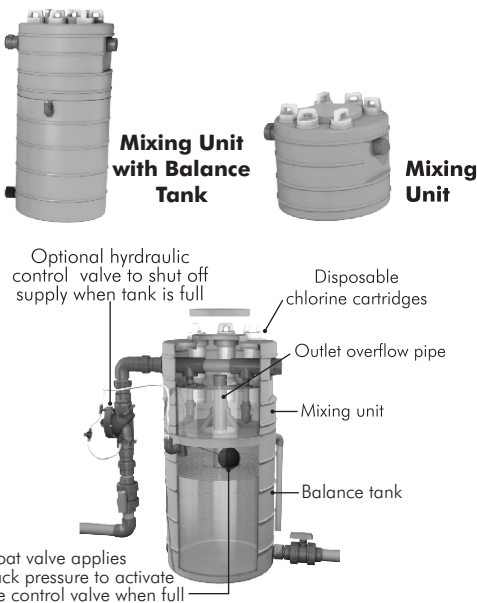

Buccaneer is a simple, versatile and effective gravity feed disinfection system that uses compacted calcium hyperchlorite chlorine cartridges for dosing free chlorine into a water flow. The cartridges are suspended in the mixing unit that is fed either directly or from a by-pass off the main flow and chlorine dosage is effected as the cartridges dissolve. Dosage rate is set by controlling either the flow through the mixing unit or by varying the number of cartridges and cartridges lift in their seats to indicate when used. Typical applications include sewage and waste water effluent, factory washdown, agricultural disinfection, food storage and potable supply.

Outflow from the mixing unit is via an overflow pipe either directly by gravity into a bulk storage tank or optionally the mixing unit can be mounted on a balance tank from which treated water can then be drawn by a pump. In this arrangement it is necessary to fit a float valve operated hydraulic valve, which stops system flow when the outflow ceases.

Buccaneer is the ideal solution for reliable and consistent unmetred chlorine dosage without the need for external power or skilled operators where assured water disinfection is required.

Dosage Capacity: Up to 6x1.9kgs refill cartridges will dose 8000m³ at 1 ppm.

Water Flow Range: Up to 7.2m³/hr direct flow

Chlorine Dosage: 1-250ppm depending on flow rate and cartridge numbers.

Maximum Inlet Pressure: 6 Bar