

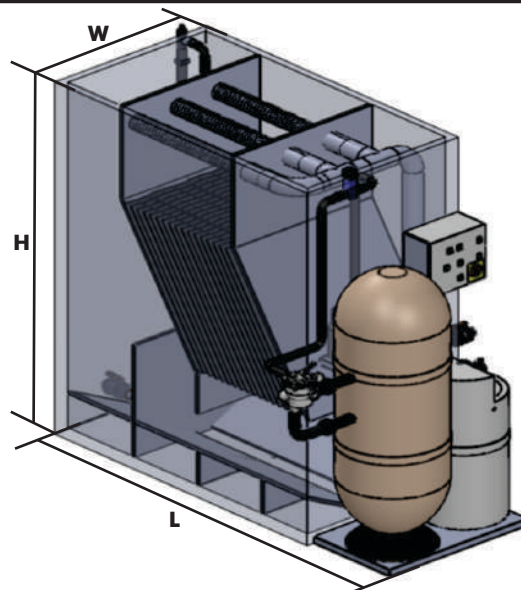

DATA SHEET

Water Treatment Plants

WL



The DAYLIFF WL range are integrated compact water treatment plants made from lightweight, non-corrosive panel sheet (polypropylene) material designed to treat surface and groundwater with high levels of suspended solids, precipitates, colour, and turbidity. The clarifier features inclined lamella tubes that offer increased surface area to volume ratio to accelerate settling of suspended matter and precipitates for ease of removal through desludging. Incorporating lamella tubes technology reduces the retention time required for settling compared to conventional clarifiers thereby significantly reducing the overall footprint of the plant.

Treatment provided incorporates conventional four-stage flocculation, sedimentation, chlorination and filtration producing high quality output that meets World Health Organisation standards for turbidity and suspended solids for drinking water.

Three basic models are available with the following features: -

- High efficiency vertical flow sedimentation basin incorporating inclined lamella tube settlers with interconnected receiving and balance tanks.
- Chemical dosage of Flocculant and Chlorine.
- Filtration through one high efficiency deep bed pressure media filter. When used with specially graded filtration media, the result is especially of high-quality filtration.
- Fully automatic operation - the quantity of water produced is automatically regulated by site demand.
- Fully integrated skid mounted units for ease of transport and simple site installation

SPECIFICATIONS

Receiving Tank

Downward flow tank with baffles for flow equalization of incoming raw water.

Sedimentation Basin

Upward flow basin with sludge bleed, integrated lamella tubes for high efficiency settling of suspended particles and precipitates.

Balance Tank

For intermediate storage of clarified water before filtration stage.

Filter

One Dayliff CXD GRP pressure filter charged with mixed bed glass and anthracite media with simple to use multiport valve and rated up to 3bar operating pressure.

Chemical Dosage

Dosage of Alum and Chlorine is included as a standard, with other chemical options being available to suit site conditions. Dosing of Alum is achieved using Dayliff Seko AML200 dosing pump drawing from a 170L GRP chemical tank, while Chlorine dosing is achieved using an inline Klorman chlorine tablets dispenser.

Filter Pump

Pedrollo centrifugal submersible pump with integral single-phase motors. Alternative equivalent models may be supplied for specific applications. Solar power option available on request.

OPERATING CONDITIONS

Raw water quality: Surface and ground waters containing suspended solids, colour, turbidity, and bacteria. The WL plants are not suitable for treatment of any dissolved solids including hardness and salinity. The effectiveness of the purification process will vary depending on the raw water quality.

Max. water temperature: 40°C

EQUIPMENT SPECIFICATION

| Model | Output (m ³ /hr) | Basin Capacity (m ³) | Balance Tank Capacity (m ³) | Standard Filter Pump | | Dimension(mm) | | | | |
|---------|-----------------------------|----------------------------------|---|----------------------|------|---------------|------|------|--------|------|
| | | | | | | Plant | | | Plinth | |
| | | | | Model | (kW) | H | L | W | PL | PW |
| WL 500 | 5 | 2.25 | 0.35 | TOP 2 | 0.37 | 2600 | 2600 | 500 | 3200 | 1100 |
| WL 1000 | 10 | 4.5 | 0.7 | TOP 3 | 0.55 | | | 1000 | | 1600 |
| WL 2000 | 20 | 9 | 1.4 | TOP 5 | 0.92 | | | 2000 | | 2600 |

KENYA
Nairobi - Head Office
 Tel: (254) 711 079 000
Nairobi - Westlands
 Tel: (254) 711 079 683/2/7/8/9
Nairobi - Downtown
 Tel: (254) 715 439 392
Eastleigh
 Tel: (254) 711 079 645
Utawala
 Tel: (254) 780 575 745
Nairobi - Karen
 Tel: (254) 726 442 342
Ongata Rongai
 Tel: (254 20) 240 0146
Kiambu
 Tel: (254) 701 646 309
Githurai
 Tel: (254) 758 727 332

Naivasha
 Tel: (254 50) 203 0510
Lodwar
 Tel: (254) 724 248 692
Eldoret
 Tel: (254) 715 590 000
Nakuru
 Tel: (254 20) 221 3248
Narok
 Tel: (254) 701 683 283
Kakamega
 Tel: (254 56) 203 1889
Kitale
 Tel: (254) 748 590 143
Bungoma
 Tel: (254) 740 048 514
Kisumu
 Tel: (254) 724 352 504
Kisii
 Tel: (254 58) 203 0949

Kericho
 Tel: (254) 780 703 197
Muranga
 Tel: (254) 780 377 682
Thika
 Tel: (254) 719 867 504
Kitengela
 Tel: (254) 705 155 522
Machakos
 Tel: (254) 712 650 283
Kitui
 Tel: (254) 701 683 289
Embu
 Tel: (254) 780 455 512
Meru
 Tel: (254 64) 313 1033
Nyeri
 Tel: (254) 799 496 253
Nanyuki
 Tel: (254 62) 203 0018

Garissa
 Tel: (254) 715 494 838
Marsabit
 Tel: (254) 748 590 140
Wajir
 Tel: (254) 780 523 728
Isiolo
 Tel: (254) 717 125 182
KENYA - COAST
Mombasa - Main Office
 Tel: (254 41) 249 0868
Mombasa - Downtown
 Tel: (254) 790 567 379
Malindi
 Tel: (254 42) 212 0425
Diani
 Tel: (254 40) 320 2181
Lamu
 Tel: (254 20) 265 1052

Nyali
 Tel: (254 20) 244 3357
Voi
 Tel: (254 20) 202 8284
Mtwapa
 Tel: (254) 798 478 113
RSWANDA
Kigali
 Tel: (250 252) 504 039
Rubavu
 Tel: (243 814) 326 631
Gakiriro
 Tel: (250 781) 182 374
SOUTH SUDAN
Juba
 Tel: (211) 927 000 020

ZAMBIA
Lusaka
 Tel: (260 211) 845 010/1
Lusaka - ChaChaCha
 Tel: (260 211) 842 350
Ndola
 Tel: (260 212) 610 936
Kitwe
 Tel: (260 212) 221 747
Livingstone
 Tel: (260 213) 320 002
Solwezi
 Tel: (260 218) 821 822
Chipata
 Tel: (260 216) 222 636
DRC
Lubumbashi
 Tel: (243) 978 115 412

UGANDA
Kampala - Main Office
 Tel: (256) 783 065 273
Kampala - Kitgum House
 Tel: (256 414) 348 337
Kampala - Nakasero
 Tel: (256 392) 734 633
Kampala - Shauri Yako
 Tel: (256 414) 660 770
Gulu
 Tel: (256 471) 433 041
Mbarara
 Tel: (256 392) 001 556
ZIMBABWE
Harare
 Tel: (263) 24 257 6246

TANZANIA
Dar es Salaam - Main Office
 Tel: (255 22) 211 2515
Dar es Salaam - Kariakoo
 Tel: (255 22) 218 4867
Arusha
 Tel: (255 27) 254 7317
Zanzibar
 Tel: (255) 774 202 069
Mwanza
 Tel: (255) 783 451 540
Dodoma
 Tel: (255) 753 506 530
ETHIOPIA (Associate)
Addis Ababa
 Tel: (251 11) 688 7925/29

