

DAVEY

DATA SHEET

Centrifugal
Pressure Pumps

XF

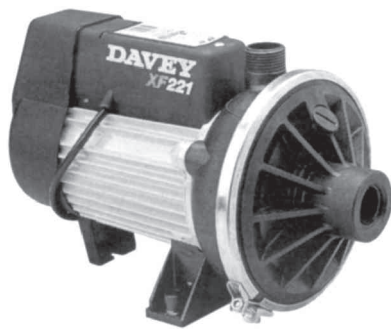

XF 171/221



XF 211SS/311SS

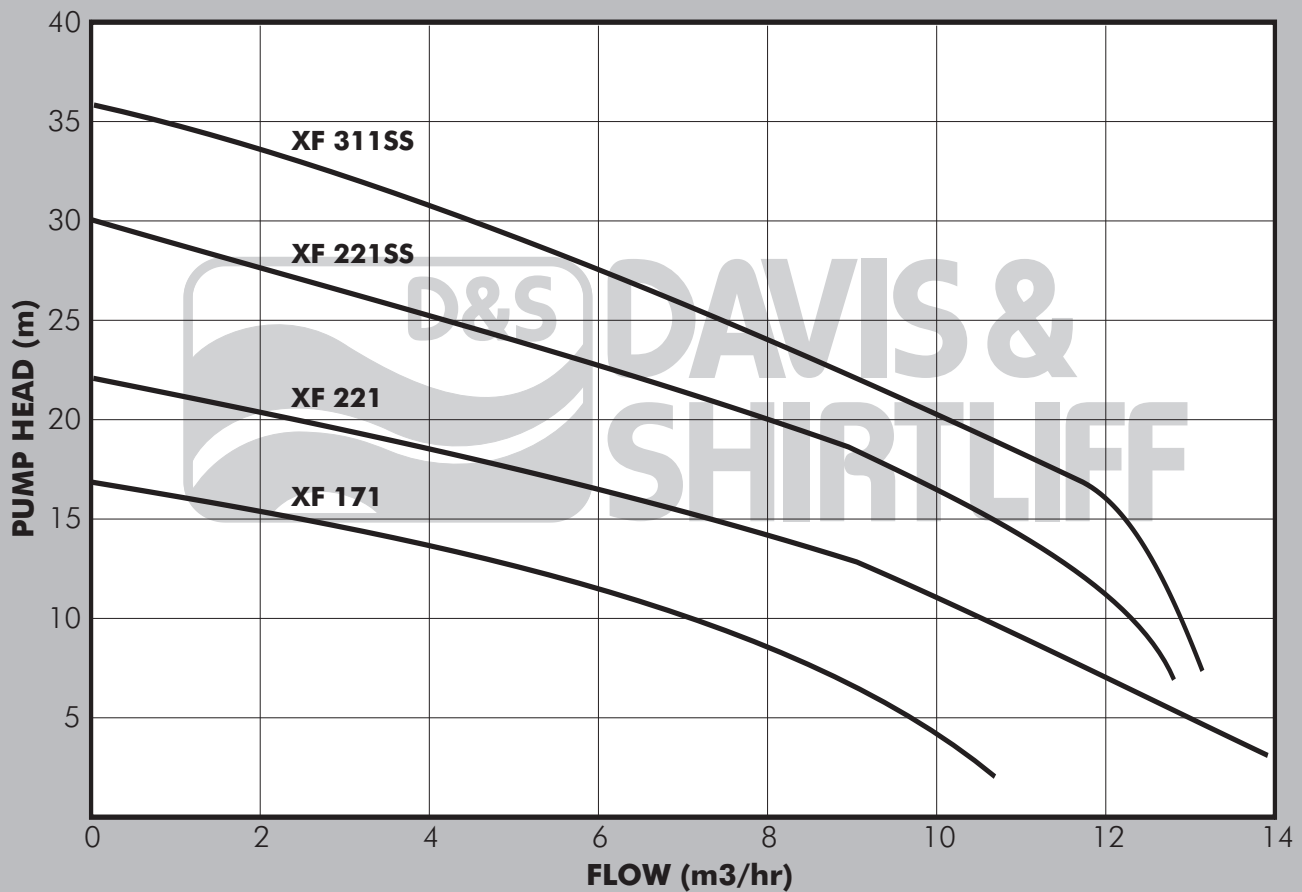

PUMP

The DAVEY XF range of booster pumps are of centrifugal single impeller design with high specification integral electric motors. They are particularly suited for water transfer in domestic, agricultural and industrial applications due to their high grade construction and continuously rated motors.

Construction material for the XF171 & XF221 is glass filled noryl for the pump casing and glass filled polycarbonate for the impeller. XF211SS and XF311SS models use 304 stainless steel for all pump components including the casing and impeller.

MOTOR

The pump includes an integral Davey TEFC permanent split capacitor type motor specified to match the hydraulic load. The motor is provided with an in-built thermal cutout for overload protection and can be connected directly to the mains power supply through a 10 Amp fuse or MCB.

Enclosure Class: IP55

Insulation Class: F

Voltage: 1 x 240V

Speed: 2900rpm

OPERATING CONDITIONS

Pumped liquid: Thin, chemically non aggressive liquids without solids or fibres.

Max Water Temperature: +50°C (XF171 and 221) 80°C (XF221/311SS)

Max Ambient Temperature: +50°C

Max Suction Lift: 7m (at sea level)

PUMP DATA

Pump	Power kW	Max Current A	Inlet BSP	Outlet BSP	Weight (Kgs)	Dimensions (mm)									
						A	B	C	D	E	H	I	J	L	N
XF 171	0.5	2.8	1" F	1" M	6.7	215	325	-	126	-	-	100	193	-	-
XF 221	0.7	4.5	1" F	1" M	8.3	215	350	-	126	-	-	100	193	-	-
XF 221SS	0.9	5.4	1¼" F	1" F	11	232	343	135	92	52	124	108	213	39	120
XF 311SS	1.1	6.4	1¼" F	1" F	14.5	260	410	176	97	51	139	121	240	39	140

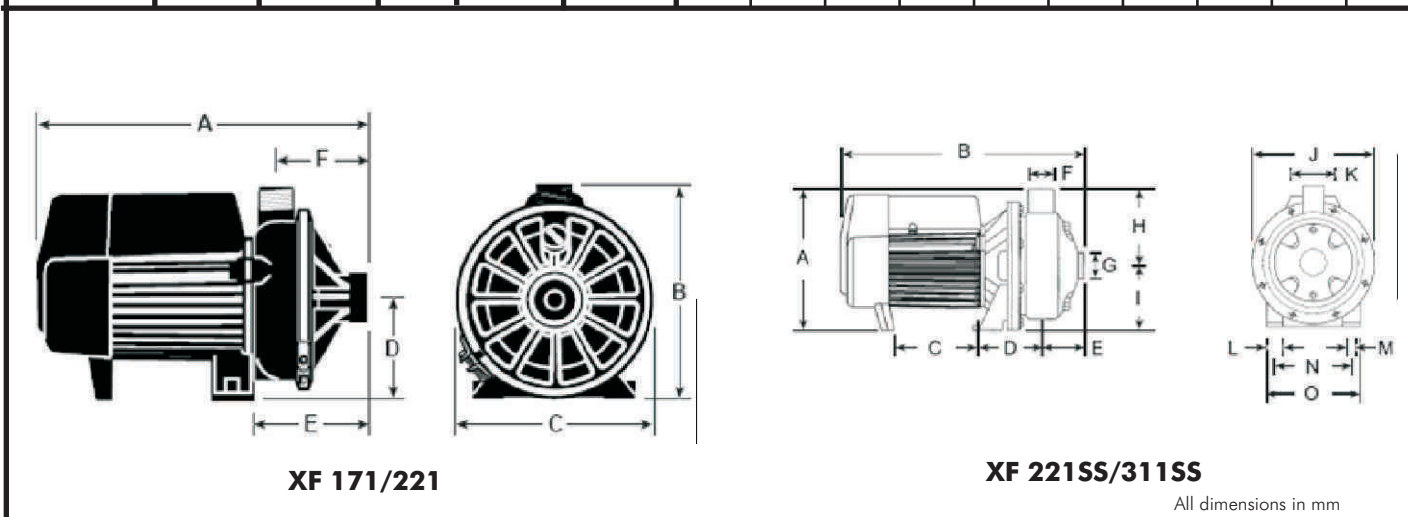

NB. Contents herein are not warranted. The right is reserved to amend specifications without notice.

DV57F-03/10

AVAILABLE FROM

D&S DAVIS & SHIRTLIFF
know How through experience
www.dayliff.com

KENYA
NAIROBI - HEAD OFFICE
TEL: (+254 20) 6968 000
d&s@dayliff.com
NAIROBI - WESTLANDS
TEL: (+254 20) 4446011/6,
westlands@dayliff.com
NAIROBI - DOWNTOWN
TEL: (+254 20) 340102
d&s@dn.dayliff.com
NAIROBI - KAREN
TEL: (+254 20) 3883513
karen@dayliff.com
THIKA
TEL: (+254 67) 20084/5
thika@dayliff.com
ELDORET
TEL: (+254 53) 2061306
eldoffice@dayliff.com

NAKURU
TEL: (+254 51) 2213248
d&s@nkr.dayliff.com
KISUMU
TEL: (+254 57) 2024763
d&s@kisumu.dayliff.com
KISII
TEL: (+254 58) 30949
d&s@kisii.dayliff.com
MERU
TEL: (+254 64) 31033
meru@eld.dayliff.com
KENYA COAST
MOMBASA
TEL: (+254 41) 2495920
d&s@msa.dayliff.com
MALINDI
TEL: (254 42) 210425
d&s@mld.dayliff.com

DIANI
TEL: (254 40) 3202181
d&s@diani.dayliff.com
LAMU
TEL: (+254 20) 2651052/56
d&s@lamu.dayliff.com
NYALI
TEL: (+254 20) 2443357
d&s@nyali.dayliff.com
ETHIOPIA
ADDIS ABABA
TEL: (+251 11) 5159341/44
d&s@et.dayliff.com
RWANDA
KIGALI
TEL: (+250) 504039, FAX: 504033
sales@dayliff.com.rw

UGANDA
KAMPALA
TEL: (+256 414) 346337/8
d&s@ug.dayliff.com
KAMPALA - NAKESERO
TEL: (+256 392) 734633
d&s@ug.dayliff.com
GULU
TEL: (+256 471) 433041
d&s@ug.dayliff.com
MBARARA
TEL: (+256) 0753 940 080
d&s@mbr.dayliff.com

TANZANIA
DAR ES SALAAM
TEL: (+255 22) 2112515/6
office@tdzdayliff.com
DAR ES SALAAM - KARIAKOO
TEL: (+255 22) 2184867
office@krk.tzdayliff.com
ARUSHA
TEL: (+255 27) 2502517/8
office@ars.tzdayliff.com
ZANZIBAR
TEL: (+255 24) 2234660/1
Office@znz.tzdayliff.com
MWANZA
TEL: (+255 28) 2541971/2
office@mwz.tzdayliff.com

ZAMBIA
LUSAKA
TEL: (+260 211) 288010/1, 845010/1
lusaka@zm.dayliff.com
KITWE
TEL: (+260 212) 221747/67
kitwe@zm.dayliff.com
NDOLA
TEL: (+260 212) 610936/7
ndola@zm.dayliff.com
LIVINGSTONE
TEL: (+260 213) 320002
livingstone@zm.dayliff.com
SOUTH SUDAN
JUBA
TEL: (+211 956) 397 070
sudan@zm.dayliff.com